

## VENTANA METROPOLITAN DISTRICT

Regular Board Meeting  
11007 Hidden Prairie Pkwy.  
Fountain, CO 80817

**Wednesday, August 11, 2021 – 10:00 a.m.**

Brian Bahr, President - Term to May 2022  
Bruce Peele, Secretary/ Treasurer - Term May 2022  
Richard Vorwaller - Term to May 2022  
Patrick Jarrett - Term to May 2023  
Jennifer Herzberg - Term to May 2023

**\*\* Please join the meeting from your computer, tablet or smartphone\*\***

<https://global.gotomeeting.com/join/622480501>

You can also dial in using your phone.

United States: +1 (646) 749-3129

Access Code: 622-480-501

**Public invited to attend**

### AGENDA

1. Call to Order
2. Declaration of Quorum/Director Qualifications/ Disclosure Matters
3. Approval of Agenda
4. Regular Business Items (These items are routine and may be approved by one motion. There will be no separate discussion of these items unless requested, in which event, the item will be heard immediately)
  - a. Approval of Board Meeting Minutes from the June 9, 2021 Meeting (attached)
  - b. Approval of Payables for the Period ending August 11, 2021 (attached)

• General Fund –	\$	44,161.21
• Bond Fund –	\$	<u>                    -</u>
• <b>TOTAL –</b>	<b>\$</b>	<b>44,161.21</b>
  - c. Acceptance of Unaudited Financial Statements as of July 31, 2021 and the schedule of cash position updated as of July 31, 2021 (attached)
5. Market Update/Construction/Operations

6. District Management Matters
  - a. Manager's Report (attached)
  - b. Review and approval for Capital items of Proposals (attached)
    - i. Street light addition at mailbox on Hidden Prairie a Cadenza
    - ii. Addition of cameras at Recreation Center
    - iii. Shade cover addition to the Park
    - iv. Shade cover addition to the Pool Deck
    - v. Additional dog stations along trails
    - vi. Replenish mulched areas
  - c. City of Fountain additional Bus stop Location (attached)
  - d. Food Trucks
  - e. Billing
    - i. July 6, 2021 bills were sent for 3<sup>rd</sup> QRT
    - ii. 8 liens remain in place to date
    - iii. 76 Reminder Letters sent on 8/3/2021
    - iv. Collection Letters will be sent on 9/2/2021
    - v. Legal counsels Lien letters will be sent around 9/16/2021
7. VCC Matters
  - a. Discussion on Board appointees for September
  - b. Discussion on Amendment to Design Guidelines – Chain link fence clarification
8. Legal Matters
9. Financial Matters
  - a. Bond Issuance Update
10. Public Comment and Public Sign-In Attendance Sheet  
(Limited to 3 minutes and only for items not on the agenda)
10. Other Business:  
  
Next Regular Meeting Date – September 8, 2021 at 10:00 AM
11. Adjourn



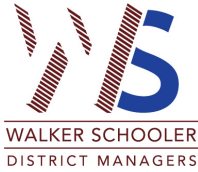

## VENTANA METROPOLITAN DISTRICT

Regular Board Meeting  
Via video and telephone conference  
**Wednesday, June 9, 2021 – 10:00 a.m.**

Brian Bahr, President - Term to May 2022  
Bruce Peele, Secretary/ Treasurer - Term May 2022  
Richard Vorwaller - Term to May 2022  
Patrick Jarrett - Term to May 2023  
Jennifer Herzberg - Term to May 2023

### MINUTES

1. Call to Order: Director Jarrett called the meeting to order at 10:04 A.M. President Bahr explained he would need to leave the meeting due to another obligation.
2. Declaration of Quorum/Director Qualifications/ Disclosure Matters: Ms. Hardekopf confirmed a quorum. All disclosures were properly filed with the Department of Local Affairs, State of Colorado by Mr. Susemihl.

Directors in attendance were:

Brian Bahr, Excused  
Richard Vorwaller  
Patrick Jarrett  
Jennifer Herzberg  
Bruce Peele, Excused

Also in attendance were:

Rebecca Hardekopf, Walker Schooler District Managers  
Kevin Walker, Walker Schooler District Managers  
Riley Walker, Walker Schooler District Managers  
Pete Susemihl, Susemihl, McDermott & Downie, P.C.  
Braden Hammond, BiggsKofford  
Members of the Public

3. Approval of Agenda: Director Vorwaller moved to approve the Agenda as presented; seconded by Director Herzberg. Motion passed unanimously.
4. Regular Business Items:
  - a. Approval of Board Meeting Minutes from the May 12, 2021 Meeting
  - b. Approval of Payables for the Period ending June 9, 2021

• General Fund –	\$	32,201.98
• Bond Fund –	\$	<u>-</u>
• <b>TOTAL –</b>	<b>\$</b>	<b>32,201.98</b>

- c. Acceptance of Unaudited Financial Statements as of May 31, 2021, and the schedule of cash position updated as of May 31, 2021

Director Herzberg moved to approve the Regular Business Items as presented; seconded by Director Vorwaller. Motion passed unanimously.

5. Market Update/Construction/Operations: Director Jarrett reported that grading work has been completed in Ventana South and the development group is still working with the City on approvals for the plans for stormwater, sanitary, and water connections. The hope is to have the first area developed and paved by the end of the year. Mr. Walker recommended the Board discuss item 8.a. before the Manager's Report. Director Herzberg moved to discuss item 8.a. before agenda item 6. District Management Matters; seconded by Director Jarrett. Motion passed unanimously.

6. District Management Matters

- a. Manager's Report: Ms. Hardekopf presented the Manager's Report. She discussed the results of the second community survey and noted the majority of residents would like a shade structure at the pool and park, Mr. Kevin Walker discussed the cost for the shade structures and noted it would qualify to be paid for by bond proceeds. Mr. Susemihl commented that he thinks it could be reimbursed by bond proceeds and would not require a reimbursement agreement. The Board agreed that shade structure at the pool is top priority, and a temporary structure would not suffice, and shade structure at the park would be the second priority. The Board directed Walker Schooler District Managers to get a bid and design plan for shade structures at the pool and park. Ms. Hardekopf discussed Rec Center operations and noted the pool was opened on May 29<sup>th</sup>. Mr. Riley Walker discussed the spa was closed for a few days due to chemical imbalances and noted the pool company has been able to resolve the issues within a day. Ms. Hardekopf discussed the list of capital improvement items. The Board requested that Walker Schooler District Managers reach back out to the landscaper on the doggie stations for a quote. There will be an evening community meeting on Tuesday, June 15<sup>th</sup> at 6 p.m.

- b. Food Trucks – June Schedule: There are not trucks scheduled to our knowledge.

- c. Billing

- April 6, 2021 bills were sent for 2<sup>nd</sup> QRT
- 13 liens filed to date
- 100 Reminder Letters will be sent on 5/3/2021
- 22 Collection Letters will be sent on 6/2/2021
- Legal counsels Lien letters will be sent around 6/17/2021

7. Legal Matters: Mr. Susemihl had no legal matters to discuss.

8. Financial Matters

- a. 2020 Audit Review with BiggsKofford: Mr. Hammond discussed the status of the Audit and noted they are nearly done and are in good shape to have it completed once approved by the Board. BiggsKofford is expecting to issue an opinion similar to prior years with a qualification related to governmental activities that relates to the balance due to OPRIC. The hope is with refinancing, this debt gets paid off and resolved so this will be the last year where that is an issue. Mr.

Hammond presented a detailed review of the 2020 Audit to the Board. Director Jarrett moved to approve the 2020 Audit draft and authorize BiggsKofford to submit the 2020 Audit once finalized; seconded by Director Vorwaller. Motion passed unanimously.

- b. Bond issuance update: Mr. Kevin Walker updated the Board on the bond issuance and noted they are waiting on the City of Fountain attorney to decide how they would like to address the issue with the service plan. Once that is resolved, they will get on the schedule for City Council. Mr. Kevin Walker noted he is hoping to be on the schedule by the end of July, finalizing the bond issue in August, and closing by September 1, 2021.
9. Public Comment: Ms. Hardekopf opened the meeting for public comment.

Mr. Josh Cooper asked about the contracts and if there are monetary penalties for not providing competent services. He gave an example. He commented that coming out the next business day is not sufficient based on the pool operating hours. He also commented that the pool is filthy, and he would like lap lanes, so he doesn't have to fight with kids to swim laps. Ms. Hardekopf explained the debris in the pool is largely due to the open field so they will be installing another privacy screen to block debris and dirt from blowing in. Lap lanes are scheduled to be installed. The pool company is at the pool daily, but recent spa issues have not been reported until the afternoon. Mr. Cooper commented on a green color in the spa due to leeching of the copper. Mr. Kevin Walker commented that if any issues are due to negligence, then they will be investigated and discussed with the contractor.

Ms. Miller asked what is being done about common areas and how often are they maintained. Ms. Hardekopf explained the landscapers are working in the community 3 times per week to maintain the common areas and park. Ms. Miller clarified that she was asking about weeds. Mr. Farrar explained that weeds are becoming a problem and are spreading into properties. Ms. Hardekopf will pass the provided photos along to the landscapers for maintenance and removal. Ms. Hardekopf pointed out that the corner lots are the responsibility of the homeowner. Mr. Kevin Walker confirmed the City of Fountain requires the adjacent property owners to maintain the corner lots, right of ways, and sidewalks.

Ms. Smith commented that there are small sprinklers along her property that backs up to green space that ran for an hour and half and wanted to know the purpose of them since there is only weed growth. Ms. Hardekopf explained it should be native grass in that area, but she will check with the landscaper. Ms. Smith also noted the weeds have overgrown the trails.

10. Other Business: Next Regular Meeting Date – 10:00 AM on July 14, 2021 via teleconference.
11. Adjournment: Director Vorwaller moved to adjourn the meeting at 10:50 a.m.; seconded by Director Herzberg. Motion passed unanimously.

Respectfully submitted,

By: \_\_\_\_\_  
Secretary for the Meeting

THESE MINUTES ARE APPROVED AS THE OFFICIAL JUNE 9, 2021 MINUTES OF  
THE VENTANA METROPOLITAN DISTRICT BY THE BOARD OF DIRECTORS  
SIGNING BELOW:

\_\_\_\_\_  
Brian Bahr, President

\_\_\_\_\_  
Bruce Peele, Secretary/ Treasurer

\_\_\_\_\_  
Rich Vorwaller, Director

\_\_\_\_\_  
Patrick Jarrett, Director

\_\_\_\_\_  
Jennifer Herzberg, Director





**Ventana Metropolitan District**  
**PAYMENT REQUEST**  
8/5/2021  
**GENERAL FUND ACCOUNT**

Company	Invoice	Date	Amount	Retainage	Amount this Draw	Comments
Biggs Kofford	104111	8/26/2021	8,400.00		\$ 8,400.00	
Comcast	8.4979E+15	8/10/2021	855.57		\$ 855.57	
City of Fountain Utilities	10005472-02	7/16/2021	6,094.02		\$ 6,094.02	Auto Pay - Rec
City of Fountain Utilities	10005630-03	7/16/2021	2,751.03		\$ 2,751.03	Auto Pay - Park
City of Fountain Utilities	10005686-02	7/16/2021	607.92		\$ 607.92	Auto Pay - Tract
City of Fountain Utilities	10006794-01	7/16/2021	3,391.10		\$ 3,391.10	Auto Pay - Tract
City of Fountain Utilities	10006795-00	7/16/2021	24.10		\$ 24.10	Auto Pay - Tract
Mailing Services Inc	15427	7/12/2021	236.67		\$ 236.67	
Signal 88, LLC	3498079	8/16/2021	980.18		\$ 980.18	
Walker Schooler District Managers	6854	7/31/2021	4,888.77		\$ 4,888.77	
We Make it Shine Ltd	21-07	9/3/2021	1,301.85		\$ 1,301.85	
Weisburg Landscape Maintenance	42675	7/20/2021	9,080.00		\$ 9,080.00	
Weisburg Landscape Maintenance	42856	7/29/2021	1,200.00		\$ 1,200.00	
Weisburg Landscape Maintenance	42749	7/31/2021	4,350.00		\$ 4,350.00	
<b>TOTAL</b>			<b>\$ 44,161.21</b>	<b>\$ -</b>	<b>\$ 44,161.21</b>	

**TOTAL FOR ALL FUNDS**

\$ 44,161.21

\_\_\_\_\_, Director



Ventana Metropolitan District  
**Balance Sheet**  
 As of July 31, 2021

	<u>Jul 31, 21</u>
<b>ASSETS</b>	
<b>Current Assets</b>	
<b>Checking/Savings</b>	
1110 · Kirkpatrick Bank	904,983.90
<b>Total Checking/Savings</b>	<u>904,983.90</u>
<b>Accounts Receivable</b>	
1-1210 · Accounts Receivable	-4,963.15
1-1230 · Property Taxes Receivable	2,654.97
<b>Total Accounts Receivable</b>	<u>-2,308.18</u>
<b>Other Current Assets</b>	
1310 · Due from Developer	32,741.59
1390 · Undeposited Funds	7,519.50
<b>Total Other Current Assets</b>	<u>40,261.09</u>
<b>Total Current Assets</b>	<u>942,936.81</u>
<b>Fixed Assets</b>	
<b>Property and Equipment</b>	
Community Improvements	441,980.56
<b>Total Property and Equipment</b>	<u>441,980.56</u>
<b>1590 · Construction in Progress</b>	
Engineering	435.00
OPRIC	738,692.00
Rivers Ventana LLC	3,972,866.28
<b>Total 1590 · Construction in Progress</b>	<u>4,711,993.28</u>
<b>Total Fixed Assets</b>	<u>5,153,973.84</u>
<b>TOTAL ASSETS</b>	<u><b>6,096,910.65</b></u>
<b>LIABILITIES &amp; EQUITY</b>	
<b>Liabilities</b>	
<b>Current Liabilities</b>	
<b>Accounts Payable</b>	
2010 · Accounts Payable	50,347.50
<b>Total Accounts Payable</b>	<u>50,347.50</u>
<b>Other Current Liabilities</b>	
2022 · Deferred Property Tax Revenue	2,654.97
2030 · Interest Payable	704,143.81
2100 · Payroll Liabilities	955.38
<b>Total Other Current Liabilities</b>	<u>707,754.16</u>
<b>Total Current Liabilities</b>	<u>758,101.66</u>
<b>Long Term Liabilities</b>	
Accrued Interest OPRIC	766,739.19
Advances from OPRIC	738,692.00
Bonds Payable - CH Metrobonds	4,464,400.00
<b>Total Long Term Liabilities</b>	<u>5,969,831.19</u>
<b>Total Liabilities</b>	<u>6,727,932.85</u>
<b>Equity</b>	
3000 · Opening Balance Equity	24,298.52
3910 · Retained Earnings	-930,685.19
Net Income	275,364.47
<b>Total Equity</b>	<u>-631,022.20</u>
<b>TOTAL LIABILITIES &amp; EQUITY</b>	<u><b>6,096,910.65</b></u>

## Ventana Metropolitan District Profit & Loss Budget vs. Actual January through July 2021

	TOTAL				
	Jul 21	Jan - Jul 21	Budget	\$ Over Budget	% of Budget
<b>Ordinary Income/Expense</b>					
<b>Income</b>					
Developer Advances	0.00	0.00	98,000.00	-98,000.00	0.0%
<b>Treasurer Taxes</b>					
Delinquent	40.83	42.12			
1-1400 · Current - O&M	33,041.15	78,152.00	78,722.61	-570.61	99.28%
1-1500 · Specific Ownership - O&M	728.49	4,532.99	5,510.58	-977.59	82.26%
2-1000 · Current- Debt	120,381.74	284,738.07	286,822.70	-2,084.63	99.27%
2-1200 · Specific Ownership - Debt	2,654.15	16,515.37	20,077.59	-3,562.22	82.26%
<b>Total Treasurer Taxes</b>	156,846.36	383,980.55	391,133.48	-7,152.93	98.17%
1-1000 · Late Fee	195.00	1,611.31	500.00	1,111.31	322.26%
<b>1-1100 · Recreation Center Dues</b>					
1-1105 · Ventana Residents	18,047.64	93,186.42	160,000.00	-66,813.58	58.24%
1-1100 · Recreation Center Dues - Other	650.23	-405.35			
<b>Total 1-1100 · Recreation Center Dues</b>	18,697.87	92,781.07	160,000.00	-67,218.93	57.99%
1-1200 · Trash Service	3,517.14	36,486.95	68,400.00	-31,913.05	53.34%
1-1300 · Rental Security Deposit	600.00	1,400.00			
1-1600 · Park Fee Advance	0.00	3,007.95			
1-180 · Covenant Violation Fine	302.00	1,280.09	500.00	780.09	256.02%
3-1300 · Park Permit Fee	0.00	1,824.00	72,360.00	-70,536.00	2.52%
<b>Total Income</b>	180,158.37	522,371.92	790,893.48	-268,521.56	66.05%
<b>Gross Profit</b>	180,158.37	522,371.92	790,893.48	-268,521.56	66.05%
<b>Expense</b>					
<b>Treasurer's Fee</b>					
1-1450 · O&M-Treasurer's Collection Fee	495.75	1,172.42	1,180.84	-8.42	99.29%
2-1050 · Debt-Treasurer's Collection Fee	1,806.21	4,271.57			
<b>Total Treasurer's Fee</b>	2,301.96	5,443.99	1,180.84	4,263.15	461.03%
1-1700 · Audit	0.00	0.00	8,300.00	-8,300.00	0.0%
1-1705 · Bank Fees	0.00	0.00	50.00	-50.00	0.0%
1-1900 · Copies & Postage	458.67	3,057.02			
<b>1-2000 · Recreation Center</b>					
1-2300 · Utilities	7,237.38	19,850.31	35,000.00	-15,149.69	56.72%
1-2301 · Management/ Operations	0.00	0.00	5,000.00	-5,000.00	0.0%
1-2302 · Cleaning Service	1,795.68	9,654.93	16,800.00	-7,145.07	57.47%
1-2305 · Security	993.57	6,497.20	12,000.00	-5,502.80	54.14%
1-2306 · Maintenance/ Repairs	190.00	1,090.00			
1-2310 · Supplies	166.77	1,123.25	4,000.00	-2,876.75	28.08%
1-2000 · Recreation Center - Other	0.00	221.85			
<b>Total 1-2000 · Recreation Center</b>	10,383.40	38,437.54	72,800.00	-34,362.46	52.8%
<b>1-2001 · Pool Expense</b>					
1-2010 · Season Start Up/ Finish	0.00	0.00	7,500.00	-7,500.00	0.0%
1-2020 · Chemicals	0.00	0.00	8,000.00	-8,000.00	0.0%
1-2030 · Summer Operations	0.00	0.00	15,000.00	-15,000.00	0.0%
1-2040 · Water	0.00	0.00	250.00	-250.00	0.0%

## Ventana Metropolitan District Profit & Loss Budget vs. Actual January through July 2021

	TOTAL				
	Jul 21	Jan - Jul 21	Budget	\$ Over Budget	% of Budget
1-2050 · Repair/ Maintenance	4,115.14	4,115.14	5,000.00	-884.86	82.3%
<b>Total 1-2001 · Pool Expense</b>	<b>4,115.14</b>	<b>4,115.14</b>	<b>35,750.00</b>	<b>-31,634.86</b>	<b>11.51%</b>
1-6160 · Dues and Subscriptions	0.00	725.05	1,000.00	-274.95	72.51%
1-6180 · Insurance	0.00	824.00	12,500.00	-11,676.00	6.59%
<b>1-6200 · Park/ Landscape</b>					
1-6205 · Maintenance	14,630.00	45,154.25	75,000.00	-29,845.75	60.21%
1-6210 · Utilities	24,231.69	31,155.23	60,000.00	-28,844.77	51.93%
<b>Total 1-6200 · Park/ Landscape</b>	<b>38,861.69</b>	<b>76,309.48</b>	<b>135,000.00</b>	<b>-58,690.52</b>	<b>56.53%</b>
1-6490 · Office Supplies	0.00	596.44	3,000.00	-2,403.56	19.88%
1-6620 · Rental Security Deposit Refund	600.00	800.00			
<b>2-6075 · Bond Expense</b>					
2-6079 · Formation	0.00	1,920.50			
2-6080 · Legal	0.00	15,194.71			
<b>Total 2-6075 · Bond Expense</b>	<b>0.00</b>	<b>17,115.21</b>			
2-6200 · Interest Expense	0.00	0.00	225,000.00	-225,000.00	0.0%
3-1400 · Construction	0.00	0.00	750,000.00	-750,000.00	0.0%
6560 · Payroll Expenses	3,465.02	26,829.07			
<b>6570 · Professional Fees</b>					
1-2500 · Trash Service	0.00	24,951.44	50,000.00	-25,048.56	49.9%
1-2701 · District Management	2,250.00	15,750.00	27,000.00	-11,250.00	58.33%
1-2705 · VCC - Covenant Enforcement	2,250.00	15,750.00	27,000.00	-11,250.00	58.33%
1-6571 · Accounting	8,400.00	8,400.00			
1-6572 · Legal Fees	0.00	7,593.00	10,000.00	-2,407.00	75.93%
1-6573 · Engineering O&M	0.00	0.00	500.00	-500.00	0.0%
<b>3-1500 · Construction Management</b>					
3-1502 · Project	0.00	0.00	50,000.00	-50,000.00	0.0%
<b>Total 3-1500 · Construction Management</b>	<b>0.00</b>	<b>0.00</b>	<b>50,000.00</b>	<b>-50,000.00</b>	<b>0.0%</b>
3-2702 · Engineering	0.00	0.00	200,000.00	-200,000.00	0.0%
<b>Total 6570 · Professional Fees</b>	<b>12,900.00</b>	<b>72,444.44</b>	<b>364,500.00</b>	<b>-292,055.56</b>	<b>19.88%</b>
<b>Total Expense</b>	<b>73,085.88</b>	<b>246,697.38</b>	<b>1,609,080.84</b>	<b>-1,362,383.46</b>	<b>15.33%</b>
<b>Net Ordinary Income</b>	<b>107,072.49</b>	<b>275,674.54</b>	<b>-818,187.36</b>	<b>1,093,861.90</b>	<b>-33.69%</b>
<b>Other Income/Expense</b>					
<b>Other Income</b>					
7030 · Other Income	0.00	223.17			
<b>Total Other Income</b>	<b>0.00</b>	<b>223.17</b>			
<b>Other Expense</b>					
8010 · Other Expenses	0.00	533.24	10,000.00	-9,466.76	5.33%
<b>Total Other Expense</b>	<b>0.00</b>	<b>533.24</b>	<b>10,000.00</b>	<b>-9,466.76</b>	<b>5.33%</b>
<b>Net Other Income</b>	<b>0.00</b>	<b>-310.07</b>	<b>-10,000.00</b>	<b>9,689.93</b>	<b>3.1%</b>
<b>Net Income</b>	<b>107,072.49</b>	<b>275,364.47</b>	<b>-828,187.36</b>	<b>1,103,551.83</b>	<b>-33.25%</b>

Income and Expense by Month  
January through July 2021

Income  
Expense

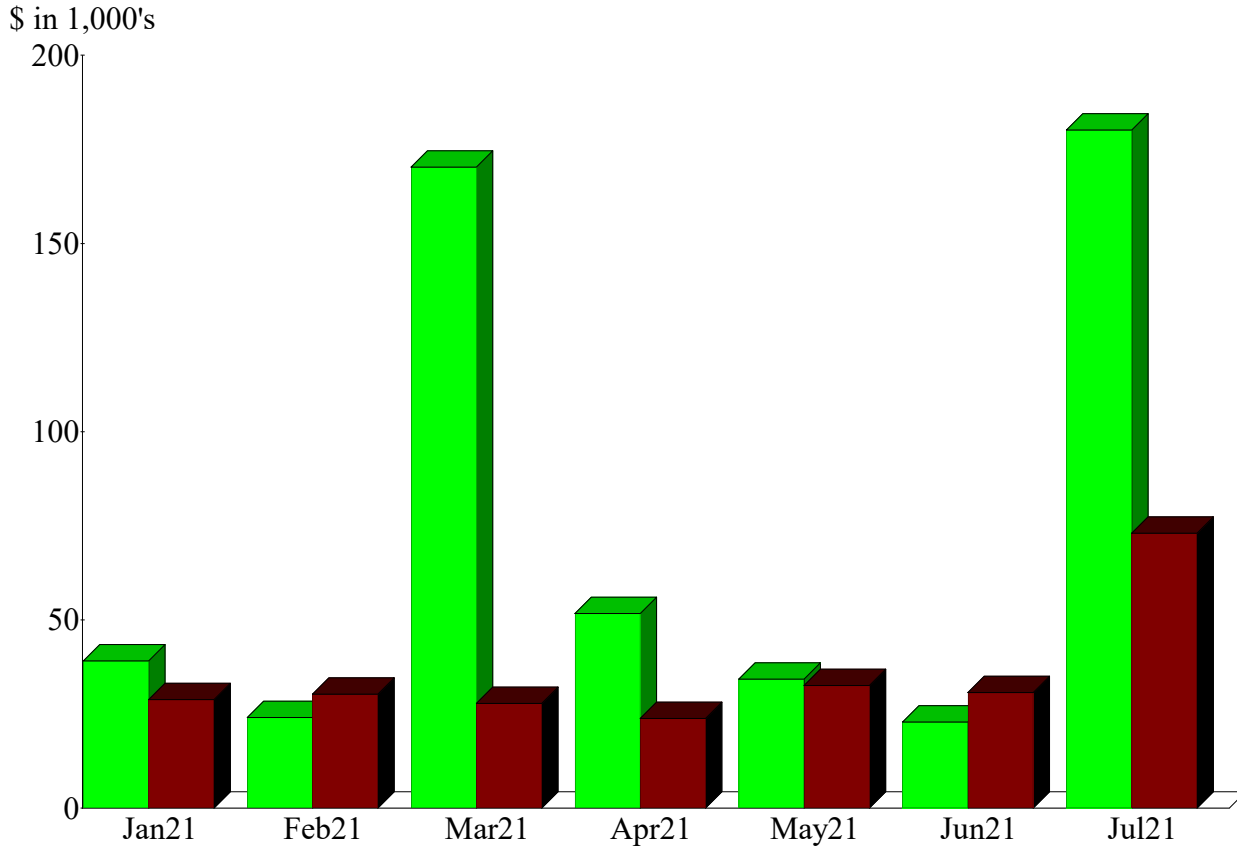

Income Summary  
January through July 2021

Treasurer Taxes	73.48%
1-1100 · Recreation Center Dues	17.75
1-1200 · Trash Service	6.98
1-1600 · Park Fee Advance	0.58
3-1300 · Park Permit Fee	0.35
1-1000 · Late Fee	0.31
1-1300 · Rental Security Deposit	0.27
1-180 · Covenant Violation Fine	0.24
7030 · Other Income	0.04
<b>Total</b>	<b>\$522,595.09</b>

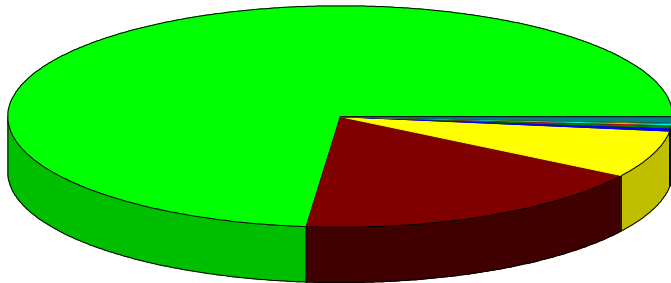

By Account

Income and Expense by Month  
January through July 2021

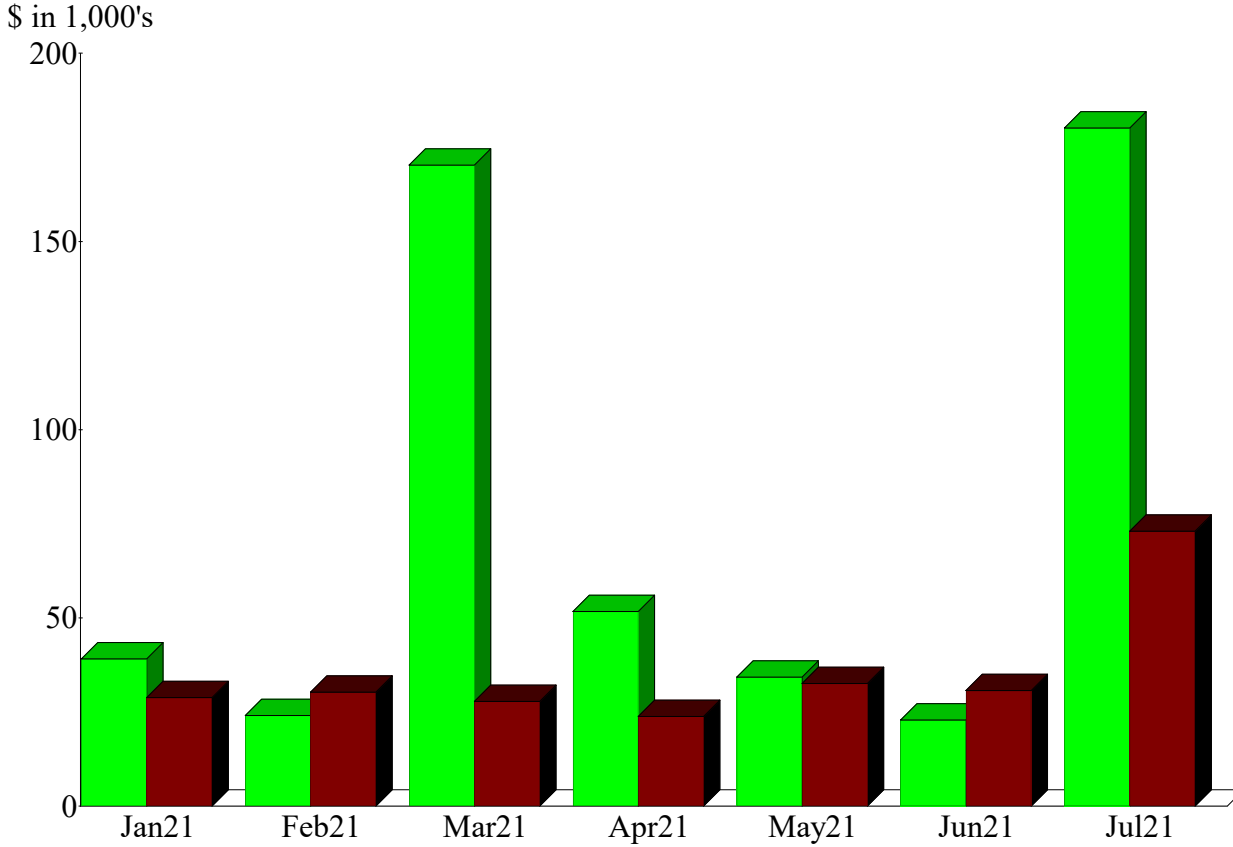
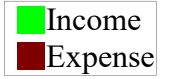

Expense Summary  
January through July 2021

1-6200 · Park/ Landscape	30.87%
6570 · Professional Fees	29.30
1-2000 · Recreation Center	15.55
6560 · Payroll Expenses	10.85
2-6075 · Bond Expense	6.92
Treasurer's Fee	2.20
1-2001 · Pool Expense	1.66
1-1900 · Copies & Postage	1.24
1-6180 · Insurance	0.33
1-6620 · Rental Security Deposit Refund	0.32
Other	0.75
<b>Total</b>	<b>\$247,230.62</b>

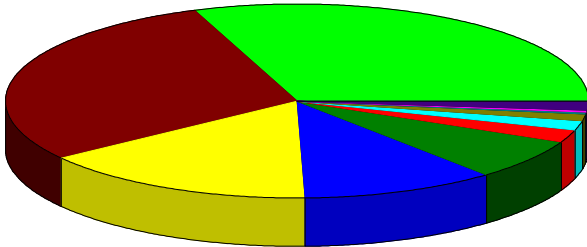

By Account





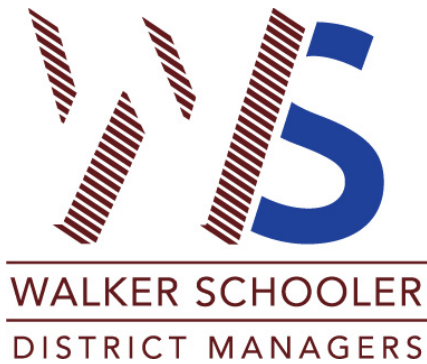

---

---

**MEMORANDUM**

---

---

**TO:** VENTANA METROPOLITAN DISTRICT BOARD OF DIRECTORS  
**FROM:** REBECCA HARDEKOPF  
**SUBJECT:** MONTHLY MANAGERS REPORT FOR AUGUST 11, 2021 MEETING  
**DATE:** AUGUST 4, 2021  
**CC:** KEVIN WALKER  
BOARD PACKET

Management matters

- Monthly newsletter went out August 4, 2021 (attached)

Recreation Center Update

- Pool Operations:
  - Spa heater issue - one of the two heating elements were broken, so it couldn't heat itself up all the way
- Recreation Center Operations
  - Great Room Rentals/ Pool Party size limits
  - Hired a new employee

Landscape Maintenance Status/ Review

- Filling 6 landscape is projected to turn over soon.

VCC Matters

- Violations issued to date 2021:
  - 361 Violations have been issued to-date.
  - 57 remain open and receiving fines
  - 1 violation remains open from previous years.

### List of Possible Capital Improvements

Based on survey response these are requested improvements for the community and Board Members response (ongoing support into cost analysis)

<b>Improvement Item</b>	<b>Board Approval</b>	<b>Cost Estimate (*not including labor)</b>	<b>Proposal Status</b>
Umbrellas/ Shade for Pool	In Favor		Being Discussed at 8/11/2021 meeting
More Dog Stations	In Favor		Being Discussed at 8/11/2021 meeting
Drainage Engineer	Already in process	(*need proposal from Contractor)	Kevin is working with Engineer
Offer "sign-up" service to maintain front properties while they are deployed	In Favor	(*need proposal from Contractor)	Pending quote from landscaper
Agility course along trail	Requested quote	(*need proposal from Contractor)	Postpone until District has funding
Shade for Park	Requested quote		Being Discussed at 8/11/2021 meeting
Storage for Pool items in winter	Requested quote	\$5,000 - \$20,000 + any permits with the City/ County	Received response and Developer will plan on this improvement
Sauna	Requested quote	\$5,000 - \$10,000 + (*need proposal from Contractor)	Postpone until District has funding
Bubble building over Pool/ Spa to keep open year-round	Look into further	\$5,000 - \$20,000 +(*need proposal from Contractor)	Postpone until District has funding
Lighting at the corner of Cadenza and Hidden Prairie	Requested quote		Being Discussed at 8/11/2021 meeting
Upgrade Security Camera system	Requested Quote		Being Discussed at 8/11/2021 meeting





*lighting > electrical > energy  
technology > signs*

## Facility Solutions Group

June 18, 2021

Attn: Rebecca Hardekopf  
Reference: Exterior Lighting at Hidden Prairie

Walker Schooler District Managers  
614 N. Tejon Street  
Colorado Springs, CO 80903

Facility Solutions Group is pleased to offer pricing for this project per the following scope of work:

- Install standalone 12ft. fiberglass pole with solar powered area light. Note, the pole will be 12ft. above the finished grade.
- Specification sheets are attached for referenced products.

**ELECTRICAL BASE PRICE    \$3,100.00 (Labor/Equipment/Misc. Material)**  
**\$1,181.00 (Fiberglass Pole)**  
**\$ 535.00 (Solar Light Fixture)**  
**\$4,816.00 (Total)**

### INCLUSIONS:

1. Supply and install (1) New Direct Burial Fiberglass Pole – Pole will be 12ft above finish grade.
2. Supply and install (1) New LED Solar powered area pole light fixture – fully functional to -4°F.
3. Quote is for normal business working hours.
4. Clean up of identifiable debris to your dumpster, final cleaning is by others.
5. Warranty based upon one (1) year for labor and material warranty per manufacture's stated.
6. All labor, material and equipment included.

### EXCLUSIONS:

1. Taxes not included.
2. Permit and engineering fees if required
3. Overtime.
4. Public service charges.
5. Any involvement with or disposal of hazardous material including fixture lamps and ballast.
6. Phone charges or equipment, data or phone cabling and terminal backboards.
7. Security devices and cabling.
8. Fire alarm.
9. Temperature Control, BAS, or Energy Management System.
10. Cutting and channeling of millwork, casework or stainless steel.
11. Cutting, patching and painting of walls, ceiling, and floors.
12. Dust control.
13. Work associated with code upgrades.
14. Any warranty work associated with owner supplied equipment.
15. Unloading and inventorying of owner supplied material.



lighting > electrical > energy  
technology > signs

Page 2

CLARIFICATIONS:

1. This proposal shall be valid for thirty days from the date of this letter.
2. If a formal contract is required, its conditions must not deviate from this proposal without our permission.
3. Anything (verbal or written) expressed or implied elsewhere, which is contrary to these conditions shall be null and void.
4. This contractor shall not be held liable for errors or omissions in designs by others, nor inadequacies of materials and equipment specified or supplied by others.
5. This contractor shall not be liable for indirect loss or damage.
6. Our pricing is based on execution of an acceptable subcontract.

*\* This budget is based on the prices of commodity products quoted to us as of the date of this proposal. Due to rapidly rising commodity material prices, this proposal is subject to increase if any of these products increase prior to the execution of a written agreement, by the amount of increases quoted by our intended suppliers and/or subcontractors. (We will provide you proof of any increase if requested.) Due to current market conditions, there is a potential for material shortages and project delays due to product availability. FSG Electric will work diligently to avoid any delays, however we can not be held responsible for delays that are out of our control.*

We appreciate the opportunity to submit this proposal. Should you have any questions, or need additional information please do not hesitate to contact us.

Sincerely,

Accepted By:

---

Rick Garcia, Project Estimator  
David Meeker, Account Manager  
Facility Solutions Group

---

Name, Title                      Date



**3000K 8 watt**

# OFF-GRID

LED SOLAR AREA LIGHT  
8W AND 30W OPTIONS

FREE TO SHINE



The Solera Solar Lighting Area Light features an all-in-one design. The solar panel, light engine and battery are built right into the LED fixture. No need for a power source, which eliminates the need for wiring and trenching.



- 8W comparable to 70W HID
- Fully programmable via remote control w/ motion sensor and photo control
- Built-in battery power indicator
- Advanced new LiFePO4 battery lasts at least 2000 charge cycles and will last three nights with one day charge (motion sensing mode)
- Perfect for parks, parking lots, school campuses, etc.
- Dimensions (L x W x H): 8W - 20" x 12" x 3"

PART #	UPC	COMPARABLE TO	LUMENS	CCT	EPA
RP-SAL-8W-50K-SF-GY-G1	844006049805	70W HID	1600	5000K	1.824
RP-SAL-30W-50K-SF-GY-G1	844006011260	250W HID	6000	5000K	4.788
TURTLE FRIENDLY SERIES					
RP-SAL-8W-AMB-SF-GY-G1	844006024376	70W HID	284	580nm AMBER	1.824
RP-SAL-30W-AMB-SF-GY-G1	844006024383	250W HID	806	580nm AMBER	4.788







7  
HRS

CHARGE TIME



UP TO  
50  
HRS

BATTERY LIFE



32°F  
TO  
149°F

BATTERY  
CHARGING TEMP



-4°F TO 122°F

OPERATING TEMP



120°

BEAM ANGLE



REPLACEABLE  
BATTERY



L70  
>100,000

RATED LIFE



5  
YEAR  
WARRANTY

WARRANTY

[solera-solar.com](http://solera-solar.com) • 847.380.3540

LIGHT EFFICIENT DESIGN HEADQUARTERS 188 S. Northwest Highway • Cary, IL 60013  
INNOVATION & MANUFACTURING CENTER 30 Log Bridge Road, Building 200 • Middleton, MA 01949  
847.380.3540 • [led-llc.com](http://led-llc.com)

08.06.20 Information is subject to change without notice.



## PART NUMBER BUILDER

MFR	PRODUCT	WATTAGE	COLOR	BRACKET	HOUSING COLOR	GEN
RP	SAL	8W	30K	SF	GY	G1

**ORDERING EXAMPLE**  
 RP-SAL-8W-50K-SF-GY-G1  
 8W  
 30W  
 SF=adjustable slip-fitter bracket GY=Grey

PLEASE NOTE, THE LEDSAL COMES STANDARD WITH THE ADJUSTABLE SLIP-FITTER BRACKET ONLY. SEE ORDERING GUIDE FOR ADDITIONAL BRACKETS AVAILABLE FOR PURCHASE.

## ORDERING GUIDE

CASE QTY	QUICK SHIP	DLC	REMPHOS PART #	QUICK SHIP UPC CODE	LUMEN OUTPUT (LM)	WATTAGE (W)	LPW	WARRANTY (YRS)	RECOMMENDED MOUNTING HEIGHT (FT)
1		N/A	RP-SAL-8W-30K-SF-GY-G1	844006011277	1600	8	200	5	UP TO 15FT
1		N/A	RP-SAL-8W-40K-SF-GY-G1	844006011260	1600	8	200	5	UP TO 15FT
1	●	N/A	RP-SAL-8W-50K-SF-GY-G1	844006011260	1600	8	200	5	UP TO 15FT
1		N/A	RP-SAL-30W-30K-SF-GY-G1	844006011260	6000	30	200	5	UP TO 30FT
1		N/A	RP-SAL-30W-40K-SF-GY-G1	844006011260	6000	30	200	5	UP TO 30FT
1	●	N/A	RP-SAL-30W-50K-SF-GY-G1	844006011277	6000	30	200	5	UP TO 30FT

ADDITIONAL BRACKETS & ACCESSORIES

ADDITIONAL BRACKETS MUST BE PURCHASED SEPARATELY.

REMPHOS PART #	DESCRIPTION
RP-SAL-BKT-8W-RP-G1	Round pole bracket for 8W
RP-SAL-BKT-8W-SP-G1	Square pole bracket for 8W
RP-SAL-BKT-8W-TN-G1	Trunnion bracket for 8W
RP-SAL-BKT-30W-RP-G1	Round pole bracket for 30W
RP-SAL-BKT-30W-SP-G1	Square pole bracket for 30W
RP-SAL-BKT-30W-TN-G1	Trunnion bracket for 30W
RP-SAL-REMOTE-G1	RP-SAL-REMOTE-G1 (remote is included standard with each fixture ordered)
RP-SAL-BIRDDGUARD	Stops birds from perching, landing or roosting on the fixture



ADJUSTABLE SLIP-FITTER BRACKET (SF)  
(included w/quick ship models)

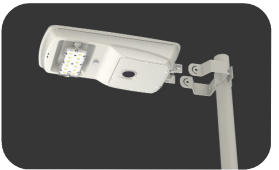

ROUND POLE BRACKET (RP)



SQUARE POLE BRACKET (SP)



TRUNNION BRACKET (TN)

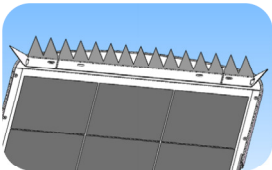

BIRD GUARD

## BRACKET GUIDE

ITEM	FIXED ARM MOUNTING	SLIP FITTER MOUNTING	U-TRUNNION MOUNTING	SQUARE-HOOP MOUNTING	ROUND-HOOP MOUNTING
8W SOLAR STREETLIGHT	 1.77" – 2.63"	 1.77" – 2.63"	 1. WALL MOUNTED 2.SQUARE POLE ABOVE 3.94"	 1. ROUND POLE: 1.96" – 3.54" 2.SQUARE POLE: 1.96" – 3.54"	 1. ROUND POLE: 1.96" – 4.33"
30W SOLAR STREETLIGHT			 1. WALL MOUNTED 2.SQUARE POLE ABOVE 4.72"	 1. ROUND POLE: 2.36" – 3.94" 2.SQUARE POLE: 1.97" – 3.94"	 1. ROUND POLE: 1.96" – 4.72"

**solera-solar.com • 847.380.3540**

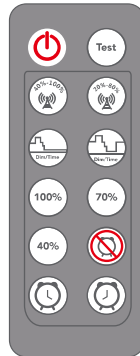
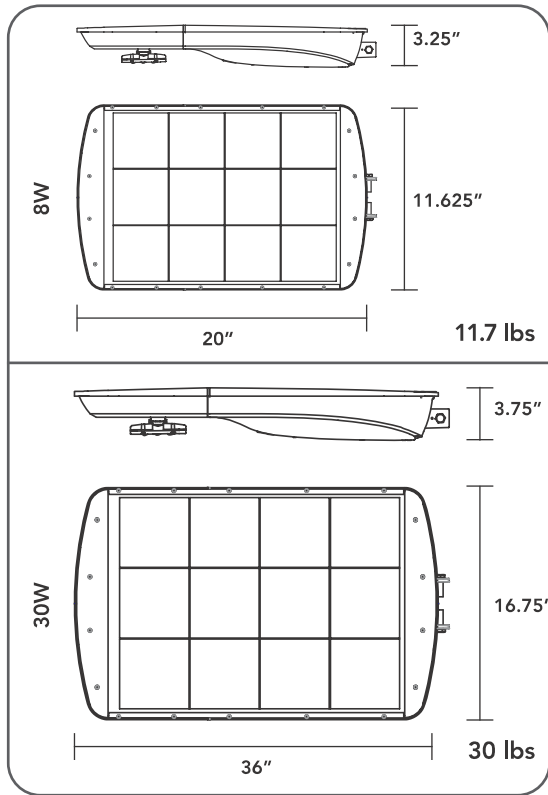

**SELECT OPERATING MODE VIA REMOTE**

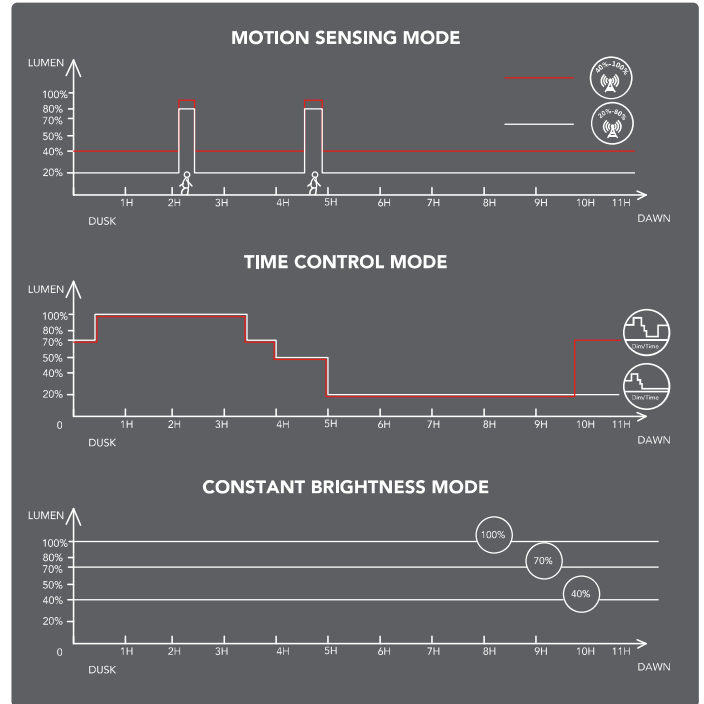

SEE INSTRUCTION MANUAL FOR MORE DETAILS ON THE AVAILABLE PROGRAMS

**PHOTOMETRICS**

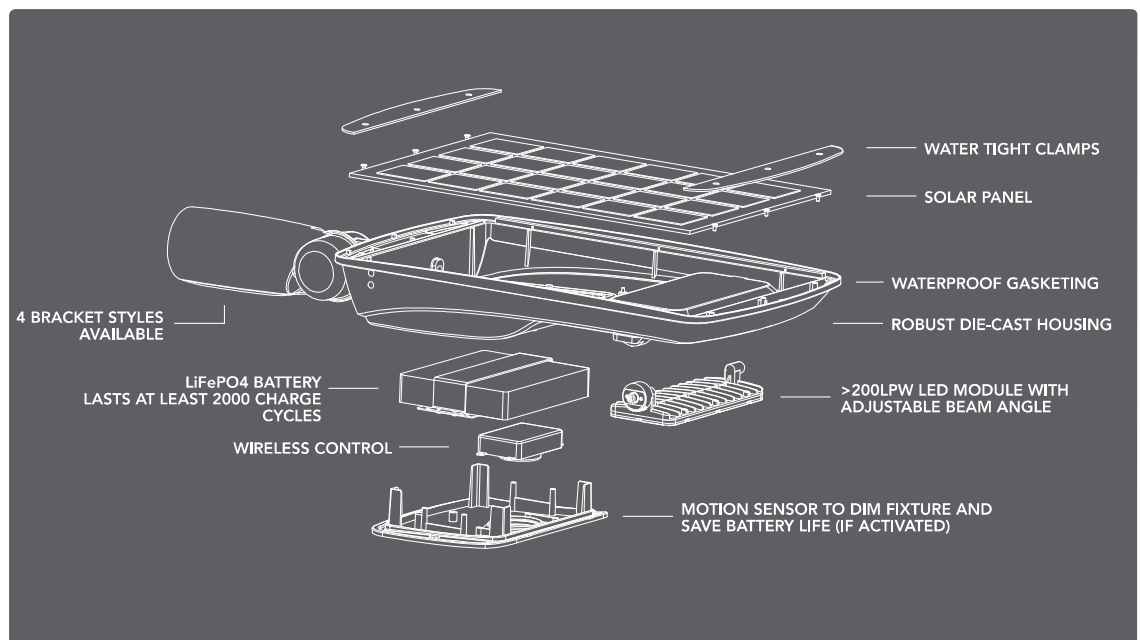
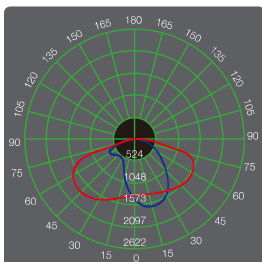
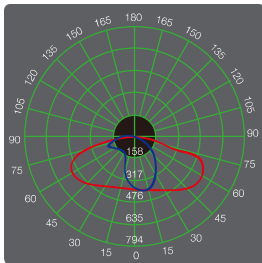

[solera-solar.com](http://solera-solar.com) • 847.380.3540



Catalog Number		12ft. black pole	
Notes		mailbox at Hidden Prairie	Type

## FEATURES & SPECIFICATIONS

**INTENDED USE** — Round tapered direct bury (embedded) fiberglass general purpose pole for up to 35 foot mounting heights.

**CONSTRUCTION** — Reinforced composite shaft incorporating "E" type fiberglass and pigmented, UV inhibiting, thermosetting polyester resin. Shaft is painted with a polyurethane top coat providing a minimum 1.5 dry film thickness and smooth surface finish.

An oval, non-metallic, 2-1/2" x 5" handhole secured with a vandal resistant, stainless steel 1/4" socket head screw. Top cap provided with all drill-mount poles. Fasteners are high-strength galvanized, zinc-plated or stainless steel.

**FINISH** — Must specify finish.



Direct Burial

# RTFDB

**ROUND TAPERED FIBERGLASS, DIRECT BURIAL**

## ORDERING INFORMATION

Lead times will vary depending on options selected. Consult with your sales representative.

Example: RTFDB 18 6X DM19 DDB

Series	Nominal fixture mounting height	Nominal shaft base size/wall thickness	Mounting <sup>1</sup>	Options	Finish <sup>7</sup>
RTFDB	14 - 35 feet (See back page.)	(See back page.)	<u>Tenon mounting</u> PT Open top T20 2-3/8" O.D. (2" NPS) T25 2-7/8" O.D. (2-1/2" NPS) <u>Drill mounting</u> <sup>2</sup> DM19 1 at 90° DM28 2 at 180° DM28PL 2 at 180° with one side plugged DM29 2 at 90° DM32 3 at 120° DM39 3 at 90° DM49 4 at 90° <u>AERIS™/OMERO™ Drill mounting</u> <sup>2,4</sup> DM19AS 1 at 90° DM28AS 2 at 180° DM29AS 2 at 90° DM32AS 3 at 120° DM39AS 3 at 90° DM49AS 4 at 90° <u>AERIS™ Suspend drill mounting</u> <sup>2,4</sup> DM19AST_ 1 at 90° DM28AST_ 2 at 180° DM29AST_ 2 at 90° DM32AST_ 3 at 120° DM39AST_ 3 at 90° DM49AST_ 4 at 90° <u>OMERO™ Suspend drill mounting</u> <sup>2,4</sup> DM19MRT_ 1 at 90° DM28MRT_ 2 at 180° DM29MRT_ 2 at 90° DM32MRT_ 3 at 120° DM39MRT_ 3 at 90° DM49MRT_ 4 at 90°	<u>Shipped installed</u> TP Tamper proof H1-18Fxx Horizontal arm bracket (1 fixture) <sup>3,5</sup> FDLxx Festoon outlet less electrical <sup>3</sup> CPL12xx 1/2" coupling <sup>3</sup> CPL34xx 3/4" coupling <sup>3</sup> CPL1xx 1" coupling <sup>3</sup> NPL12xx 1/2" threaded nipple <sup>3</sup> NPL34xx 3/4" threaded nipple <sup>3</sup> NPL1xx 1" threaded nipple <sup>3</sup> EHHxx Extra handhole <sup>3,6</sup>	<u>Standard colors</u> DDB Dark bronze DWH White DBL Black DMB Medium bronze DNA Natural aluminum <u>Classic colors</u> DSS Sandstone DGC Charcoal gray DTG Tennis green DBR Bright red DSB Steel blue <u>Architectural colors</u> (powder finish) <sup>7</sup>

### HANDHELD ORIENTATION

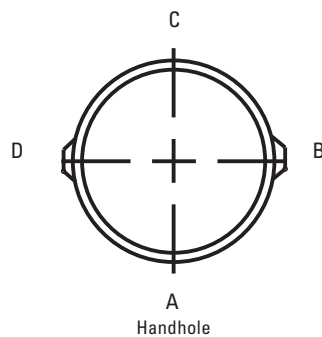

**NOTES:**

- When ordering tenon mounting and drill mounting for the same pole, follow this example: DM28/T20. The combination includes a required extra handhole.
- The drilling template to be used for a particular luminaire depends on the luminaire that is used. Refer to the Technical Data Section of the Outdoor Binder for Drilling Templates.
- Specify location and orientation when ordering option.  
For 1st "x": Specify the height in feet above base of pole.  
Example: 5ft = 5 and 20ft = 20  
For 2nd "x": Specify orientation from handhole (A,B,C,D)  
Refer to the Handhole Orientation diagram on this page.
- Insert "1" or "2" to designated fixture size; e.g. DM19AST2.
- Horizontal arm is 18" x 2-3/8" O.D. tenon standard and includes extra handhole.
- Combination of tenon-top and drill mount includes extra handhole.
- Finish must be specified. Additional colors available; see [www.lithonia.com/archcolors](http://www.lithonia.com/archcolors) or Architectural Colors brochure (Form No. 794.3).

**IMPORTANT INSTALLATION NOTES:**

- Do not erect poles without having fixtures installed.
- If poles are stored outside, all protective wrapping must be removed immediately upon delivery to prevent finish damage.
- Lithonia Lighting is not responsible for the foundation design.

# RTFDB Round Tapered Fiberglass Poles - Direct Burial

## TECHNICAL INFORMATION

Catalog Number	Nominal fixture mounting height (feet)	Pole shaft size (in x in x ft)	EPA (ft <sup>2</sup> ) with 1.3 gust			Max. weight	Approximate ship weight (pounds)
			80 mph	90 mph	100 mph		
<b>RTFDB 18 6X</b>	14	6.5 x 4.1 x 18	14.0	10.4	7.9	150	34
<b>RTFDB 20 6-6X</b>	16	6.7 x 4.1 x 20	10.0	7.4	5.5	100	38
<b>RTFDB 24 6-7X</b>	20	6.7 x 4.1 x 24	8.2	5.8	4.1	150	46
<b>RTFDB 30 8-3X</b>	25	8.2 x 4.5 x 30	6.2	4.7	3.6	100	71
<b>RTFDB 30 8-4X</b>	25	8.4 x 4.7 x 30	14.5	11.2	8.9	200	98
<b>RTFDB 35 8-4X</b>	30	8.4 x 4.7 x 35	10.5	8.0	6.2	200	116
<b>RTFDB 35 8-5X</b>	30	8.5 x 4.9 x 35	14.8	11.4	9.0	300	153
<b>RTFDB 41 11-8X</b>	35	11.8 x 6.4 x 41	14.3	10.8	7.8	300	218

## POLE DETAIL

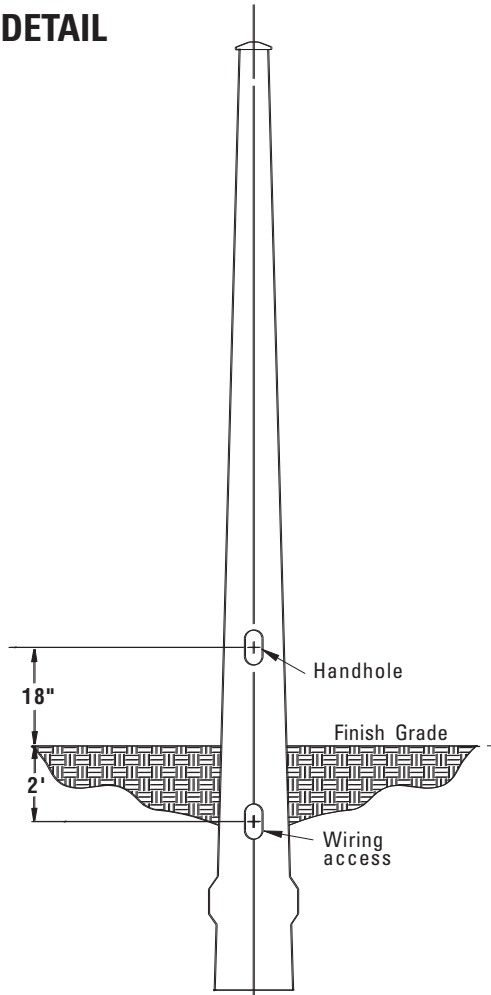

### IMPORTANT:

- These specifications are intended for general purposes only. Lithonia reserves the right to change material or design, without prior notice, in a continuing effort to upgrade its products.





# datavoice

## OPTIONS

QUOTE NUMBER

1937

DATE

June 23, 2021

VALID UNTIL

July 23, 2021 at 11:19PM

FROM

Data Voice Options Quotes  
Data Voice Options, LLC  
8605 Explorer Drive Suite 250  
Colorado Springs, CO 80920  
[www.datavoiceoptions.com](http://www.datavoiceoptions.com)

PHONE

720-900-1111

FOR

Ventana Metropolitan District

TO

Rebecca Hardekopf

EMAIL

[rebecca.h@wsdistricts.co](mailto:rebecca.h@wsdistricts.co)

## Ventana Clubhouse Camera System Upgrade

### CAMERA SYSTEM and CABLE HARDWARE

<b>HW-LV-CAT6-PLN</b> CAT6E Plenum 23/4PR CMP 550mhz 1000ft spool	392.00 x 1 392.00
<b>HW-LV-KSTN-CAT6</b> CAT6 Keystone Jack RJ45 Ethernet Connector	5.20 x 4 20.80
<b>HW-LV-CABLE-HW</b> Cabling hardware for OSHA requirements, cable management and cable pathway	50.00 x 1.5 75.00
<b>DAH-NVR-16CH</b> Dahua - 16Ch. Smart H.265+ and H.264 Dual Codecs Maximum 320 Mbps Incoming Bandwidth Up to 12 MP Resolution for Preview and Playback Ports 1 to 8 Support ePoE and EoC Signal Transmission, up to 800 m (2524 ft) HDMI and VGA Simultaneous Video Output Intelligent Video System	829.00 x 1 829.00
<b>DAH-4MP-DOM</b> The 4 MP mini dome camera features an advanced 1/3-in. Progressive-scan imager with a 3.6 mm fixed lens. The camera offers True Wide Dynamic Range, a True Day/Night IR Cut filter, IP67 Ingress Protection and operation in extreme temperatures to deliver superior images	162.00 x 3 486.00

<p><b>DAH-5MP-FISH</b></p> <p>2592 x 1944 Resolution at 30 fps  1.4mm Fixed Lens  360° Horizontal Field of View  Two-Way Audio  Supports microSD Cards up to 256GB  Complies with ONVIF Profiles G, S &amp; T  IP67 Rated for Outdoor Use  IK10-Rated Vandal Resistance</p>	<p>384.57  x 1  384.57</p>
<p><b>DAH-CAM-MNT</b></p> <p>Dahua camera mount kit.</p>	<p>38.00  x 4  152.00</p>
<p><b>HW-LV-MISC</b></p> <p>Low-Voltage related hardware purchase  8 TB NVR Harddrive</p>	<p>316.67  x 1  316.67</p>
<p style="text-align: right;">Subtotal</p>	<p>2,656.04</p>

**CAMERA SYSTEM and CABLE LABOR**

<p><b>SVC-LV-ETH-DMARC-FIN</b></p> <p>Ethernet Cat5e/6 cabling run for DEMARC and unfinished surface. Professionally installed using necessary hardware per OSHA standards. All cabling allows for at least a six-inch service loop and is tested for continuity.</p>	<p>190.00  x 4  760.00</p>
<p><b>SVC-SEC-CAM</b></p> <p>"Configuration of Camera and Mount  - Mount camera junction box  - Mount camera into junction box with weatherproof sleeve  - Confirm network connectivity  - Set IP and network configuration  - Set VLAN where applicable  - Adjust camera angle and 'noise'  - Add camera to NVR system"</p>	<p>125.00  x 4  500.00</p>

<p><b>SVC-SEC-NVR</b></p> <p>Configuration of NVR System</p> <ul style="list-style-type: none"> <li>- Mount NVR equipment</li> <li>- Set user credentials</li> <li>- Set IP and network configuration</li> <li>- Set VLAN where applicable</li> <li>- Open ports for user accessibility</li> <li>- Configure recording times, camera layout, users/permissions</li> <li>- Update firmware</li> <li>- Adjust view of cameras</li> <li>- Setup remote terminals</li> <li>- Work with user(s) to setup access via phone/tablet app</li> </ul>	<p>1,250.00 x 1 50% discount 625.00</p>
<p>Subtotal</p>	<p>1,885.00</p>

<p>Subtotal, includes discount of 625.00</p>	<p>4,541.04</p>
<p>Tax 8.25%</p>	<p>219.14</p>
<p><b>Total including tax</b></p>	<p><b>\$4,760.18</b></p>





Go Play, Inc  
 Jennifer and David VanWormer  
 9916 County Road 48 1/2  
 Milliken, CO 80543

Playground  
 Cantilever shade  
**Proposal**

Customer	
Name	Ventana Metro District - c/o Walker Schooler District Mng.
Address	614 N. Tejon Street
City	Colorado Springs State CO ZIP 80903
Phone	(719)447-1777 ext. 103 (Rebecca Hardekopf)

Misc	
Date	6/22/2021
Order No.	SRPSSQ21
Rep	JWW
FOB	

Qty	Description	Unit Price	TOTAL
3	<b>EQUIPMENT:</b> Superior Shade 12' x 12' square, single-post cantilever shade umbrella, 8' eave height, 6" sub-surface mount.  FRAME COLOR - _____ SHADE FABRIC COLOR - _____	\$5,015.00	\$ 15,045.00
1	<b>Superior Shade Q2/Q3 Sale on 12' Square Cantilever Umbrella</b> <i>(Sale price valid on orders placed with deposit by September 17, 2021. May not be combined with any other discounts or promotions.)</i>	20%	\$ (3,009.00)
1	Sealed engineered drawings (1 set per style and location needd)	\$700.00	\$ 700.00
1	Manufacturer's steel surcharge <i>(If order is placed with deposit by 7/11/21, deduct \$600 )</i>		\$ 1,525.00
3	<b>INSTALLATION:</b> Completed installation of shade structures above by Go Play, Inc. including (1) standard size footing not to exceed 3.5' diameter x 3' depth, one mobilization to site and complete installation of frame and canopy.  <u>Installation location:</u> Ventana Playground Area 10942 Hidden Prairie Parkway Fountain, CO 80817	\$3,150.00	\$ 9,450.00
<b>NOTES:</b> Signature below indicates approval of order for size, style and color of shades described above. Installation price assumes adequate access to site for large installation machinery and does not include turf protection. No site preparation, locating or repairing existing drain or sprinkler lines, fencing, security, concrete cutting, concrete patching or flatwork, removal or disposal of spoils, nor site restoration are included. Should sealed engineered drawings require larger than standard size footings for this location, additional fees will apply. No permits, licenses, taxes, or associates fees are included. Current lead time on seals is running 4 weeks and productions is 6-8 weeks. Lead times may vary without notice due to shartages in the supply chain.			

**Signed proposal and 50% deposit is required to proceed with order.**

Date \_\_\_\_\_

Tax Rate(s)

Authorizing Signature \_\_\_\_\_

SubTotal	\$ 23,711.00
Freight	\$ 2,265.00
2.90%	exempt
<b>Total</b>	<b>\$ 25,976.00</b>

Tax Exempt # \_\_\_\_\_ \*

*\*If customer is not exempt from sales tax, applicable tax will be added to materials.*

Office Use Only



CONTACT- Go Play Phone (970) 587-5963  
 Go Play Email [jennifer@goplayplaygrounds.com](mailto:jennifer@goplayplaygrounds.com)



Thank you for your consideration! Quoted pricing is valid for 30 days unless otherwise noted.



# Square Cantilever Umbrella Shade

Length	12	Width	12	Entry Height	8
Peak Height	10.42	Elbow	Standard	Column Mount	Base Plate
Column Size	5050.25	Rafter Size	2.875011	Ridge Size	2.875011
Column Length	8.5	Rafter Length	8.83883476	Ridge Length	0

Dome Qty: 1 Column Qty: 1

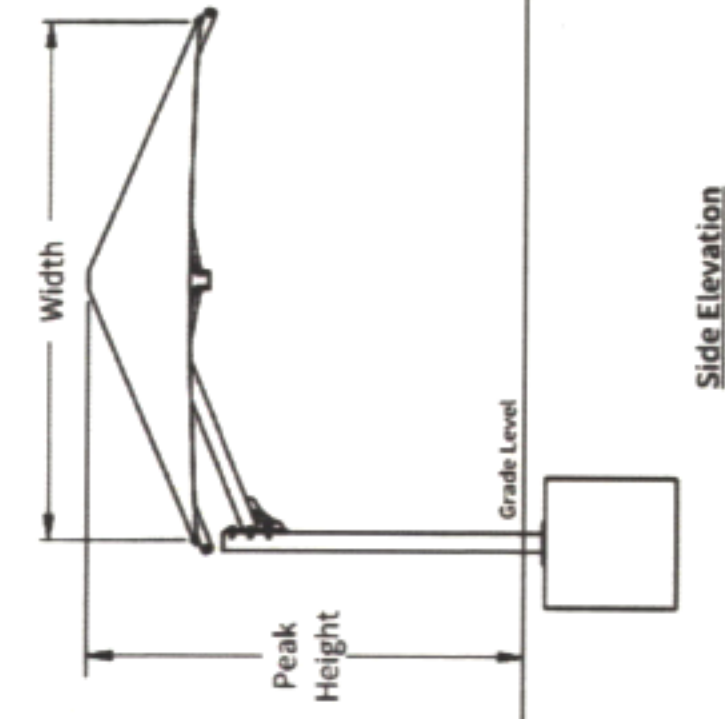
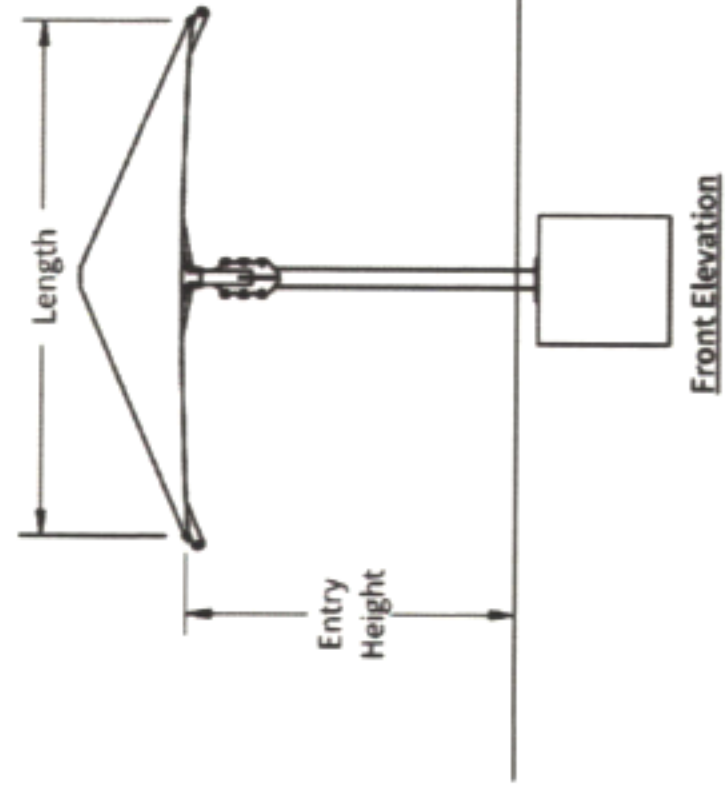
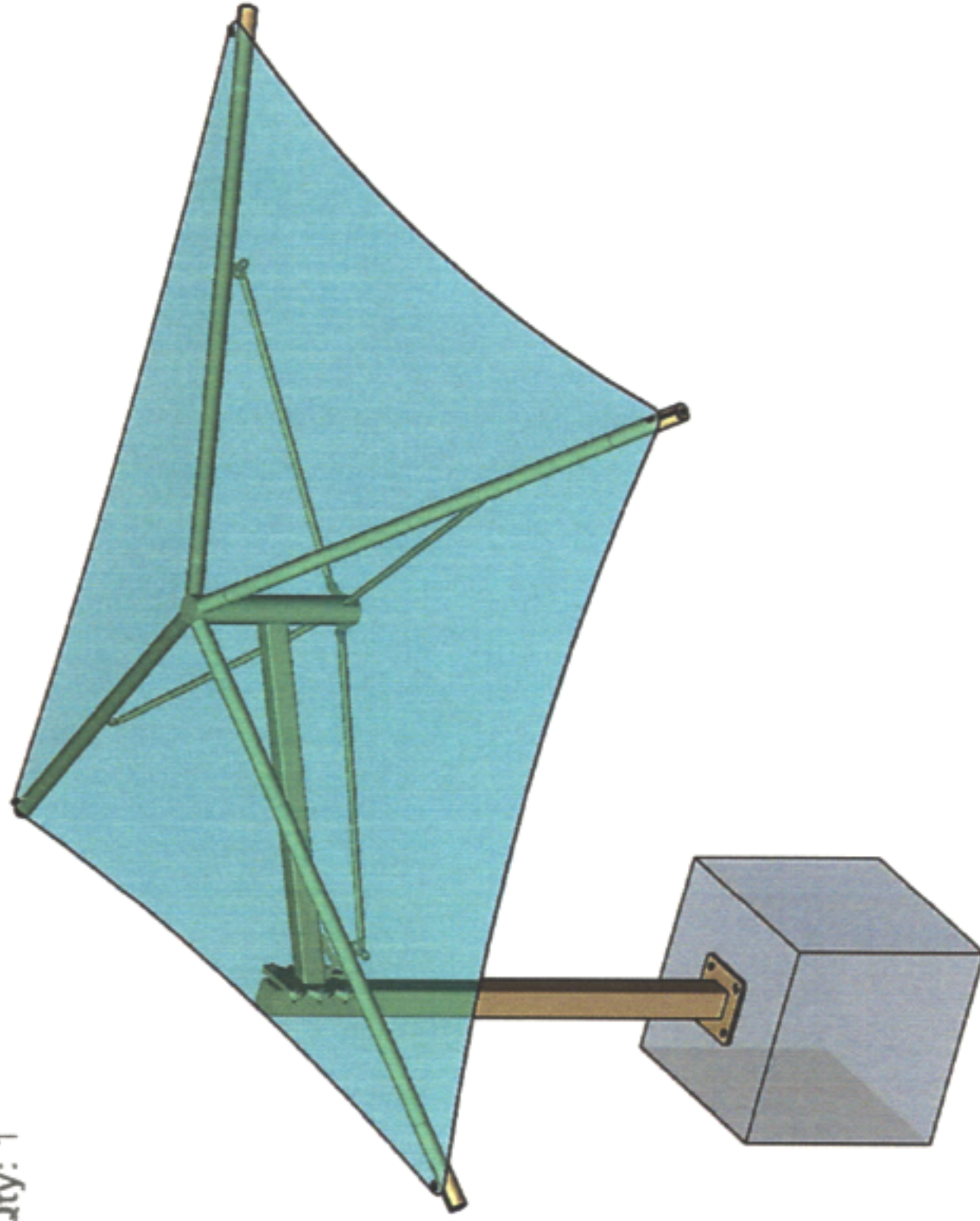

Square Footing		
Column	Length & Width	Depth
Single Cap	3.34	3
Double Cap	N/A	3

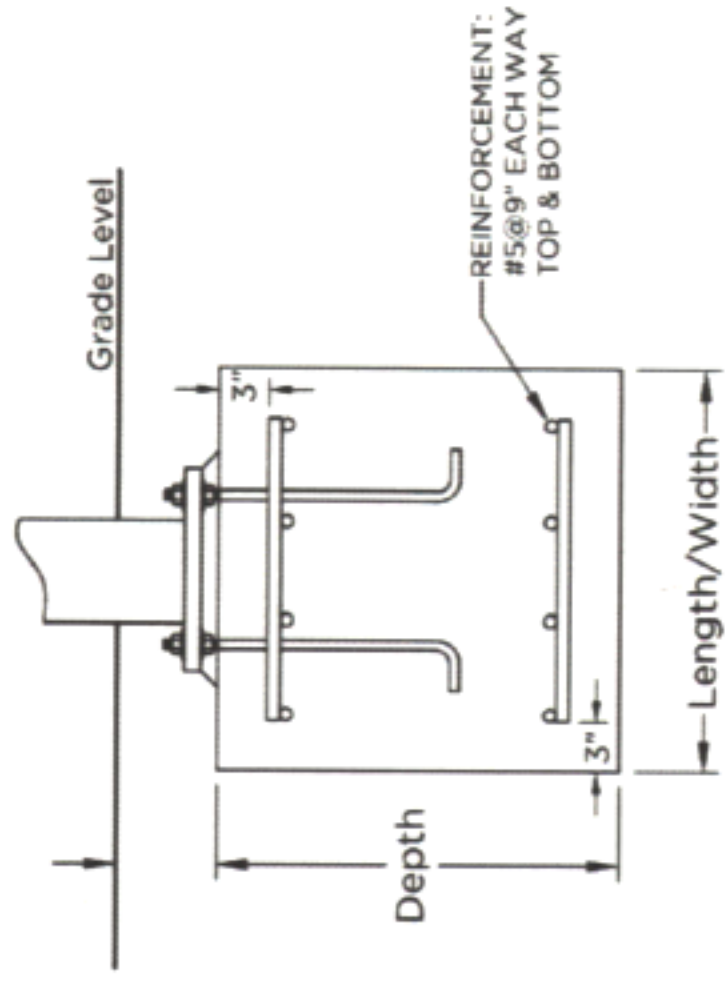

Auger Footing		
Diameter	Single Cap Depth	Double Cap Depth
1'-6"		
2'-0"	Out of range	N/A
2'-6"	5.45	N/A
3'-0"	3.78	N/A

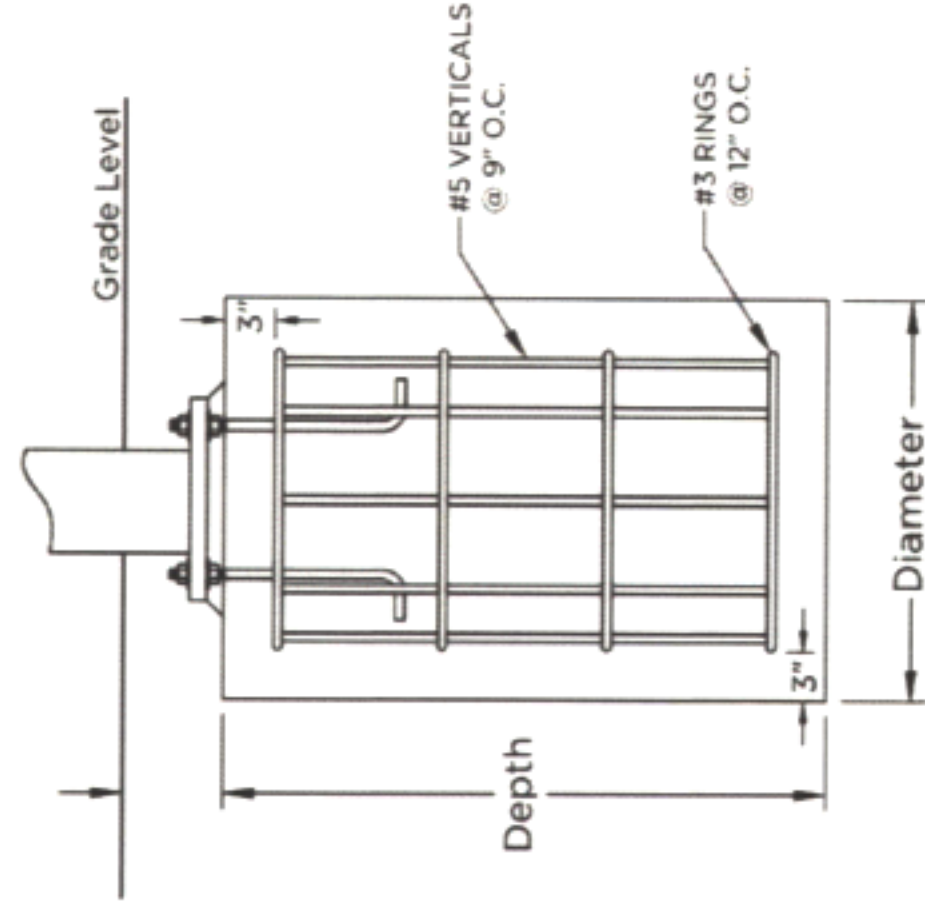

# SHADE

BY SUPERIOR RECREATIONAL PRODUCTS

QUOTE

SHADE SIZE  
12 X 12

SHADE STYLE  
Square Cantilever  
Umbrella Shade

*These drawings are for reference only and should not be used as construction details. They show the general character and rough dimensions of the structural features. Exact spans, fasteners, materials, and foundations can be determined by a licensed professional engineer upon request. Estimated footing size above is based on 1,500 PSF soil bearing pressure.*



# Ventana Metro District Playground Shades

GO PLAY, INC.  
Jennifer VanWormer  
(970) 587-5963  
jennifer@goplayplaygrounds.com

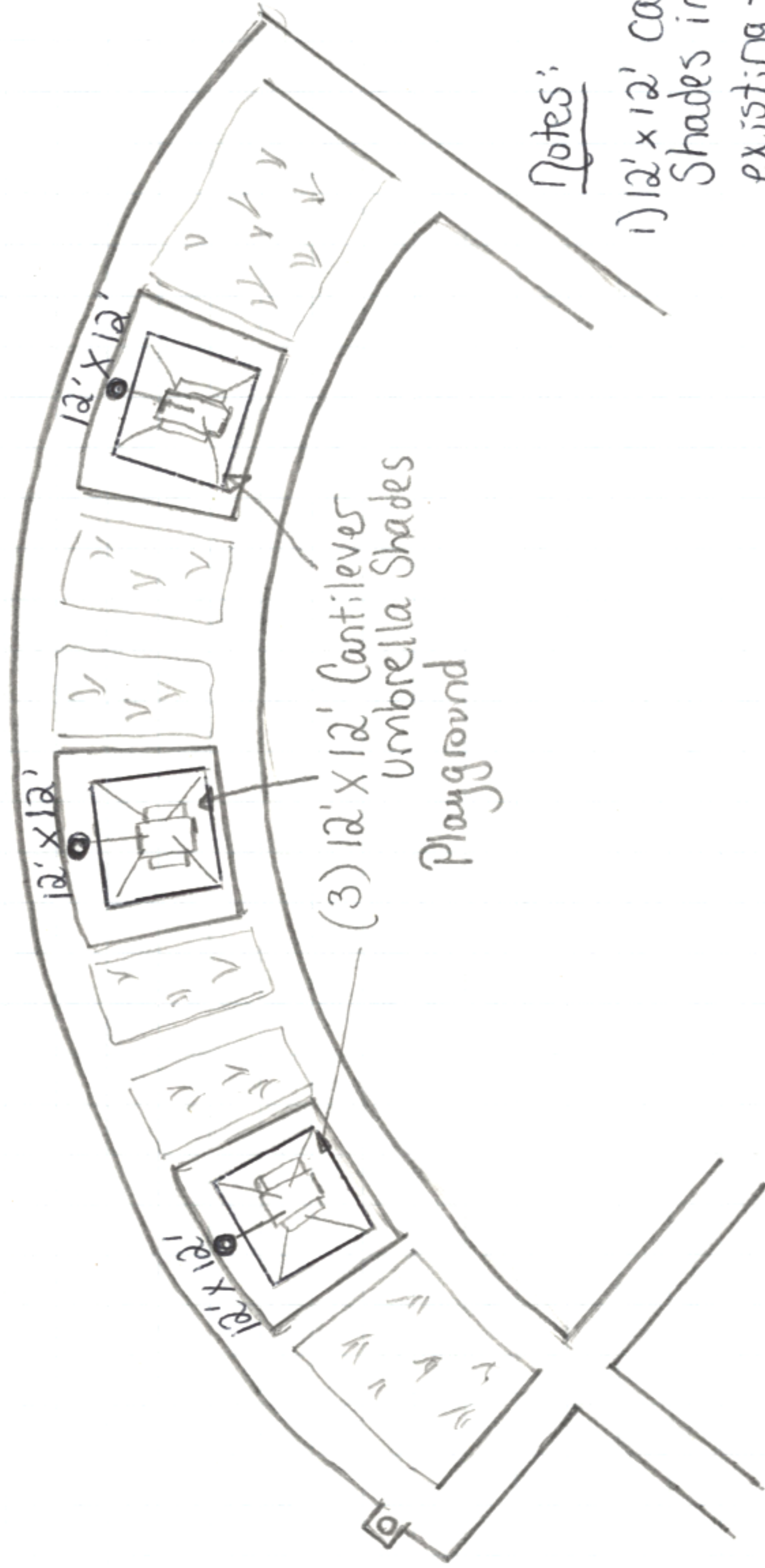

## Notes:

- 1) 12' x 12' Cantilever Shades installed in existing table pits.
- 2) Disposal of spoils on site.

Scale 1" = 20'

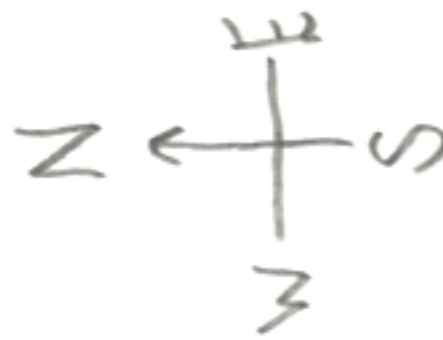



Go Play, Inc  
 Jennifer and David VanWormer  
 9916 County Road 48 1/2  
 Milliken, CO 80543

Playground  
**SHELTER**

**Proposal**

Customer	
Name	Ventana Metro District - c/o Walker Schooler District Mng.
Address	614 N. Tejon Street
City	Colorado Springs State CO ZIP 80903
Phone	(719)447-1777 ext. 103 (Rebecca Hardekopf)

Misc	
Date	6/22/2021
Order No.	SRPSS201
Rep	JVW
FOB	

Qty	Description	Unit Price	TOTAL
1	<b>EQUIPMENT:</b> Superior Shelter 20' x 20' square square hip shelter, 6:12 pitch, 7' 6" eave height, 6" sub-surface mount, (4) standard column design in standard color option (includes manufacturer's steel surcharge)  FRAME COLOR - _____ ROOF COLOR - _____	\$21,995.00	\$ 21,995.00
1	<b>Go Play Discount on 20' Square Hip Shelter</b> <i>(May not be combined with any other discounts or promotions.)</i>	5%	\$ (1,099.75)
1	Sealed engineered drawings	\$1,250.00	\$ 1,250.00
1	<b>INSTALLATION:</b> Complete installation of shelter above by Go Play, Inc. including (4) standard size footings not to exceed 3.5' diameter x 3' depth, one mobilization to site and complete installation of frame and roofing.  <b>Installation location:</b> <u>Ventana Playground Area</u> <u>10942 Hidden Prairie Parkway</u> <u>Fountain, CO 80817</u>  <b>NOTES:</b> Signature below indicates approval of order for size, style and color of shelter as described above. Installation price assumes adequate access to site for large installation machinery and does not include turf protection. No site preparation, locating or repairing existing drain or sprinkler lines, fencing, security, concrete cutting, concrete patching or flatwork, removal or disposal of spoils, nor site restoration are included. Should sealed engineered drawings require larger than standard size footings for this location, additional fees will apply. No permits, licenses, taxes, or associates fees are included. It is the customer's responsibility to verify any local building department zoning or permitting requirements prior to placing order. No "flooring" nor site furnishings are included with this proposal, but may be added if desired. Current lead time on seals is running 6 weeks and productions is 14-16 weeks. Lead times may vary without notice due to shortages in the supply chain and workforce.	\$9,850.00	\$ 9,850.00

**Signed proposal and 50% deposit is required to proceed with order.**

Date \_\_\_\_\_

Tax Rate(s)

Authorizing Signature \_\_\_\_\_

SubTotal	\$	31,995.25
Freight	\$	3,580.00
2.90%		exempt
<b>Total</b>	<b>\$</b>	<b>35,575.25</b>

Tax Exempt # \_\_\_\_\_ \*

\*If customer is not exempt from sales tax, applicable tax will be added to materials.

Office Use Only



**CONTACT- Go Play Phone (970) 587-5963**  
**Go Play Email [jennifer@goplayplaygrounds.com](mailto:jennifer@goplayplaygrounds.com)**



Thank you for your consideration! Quoted pricing is valid for 30 days unless otherwise noted.

# Ventana Metro District Playground Shelter

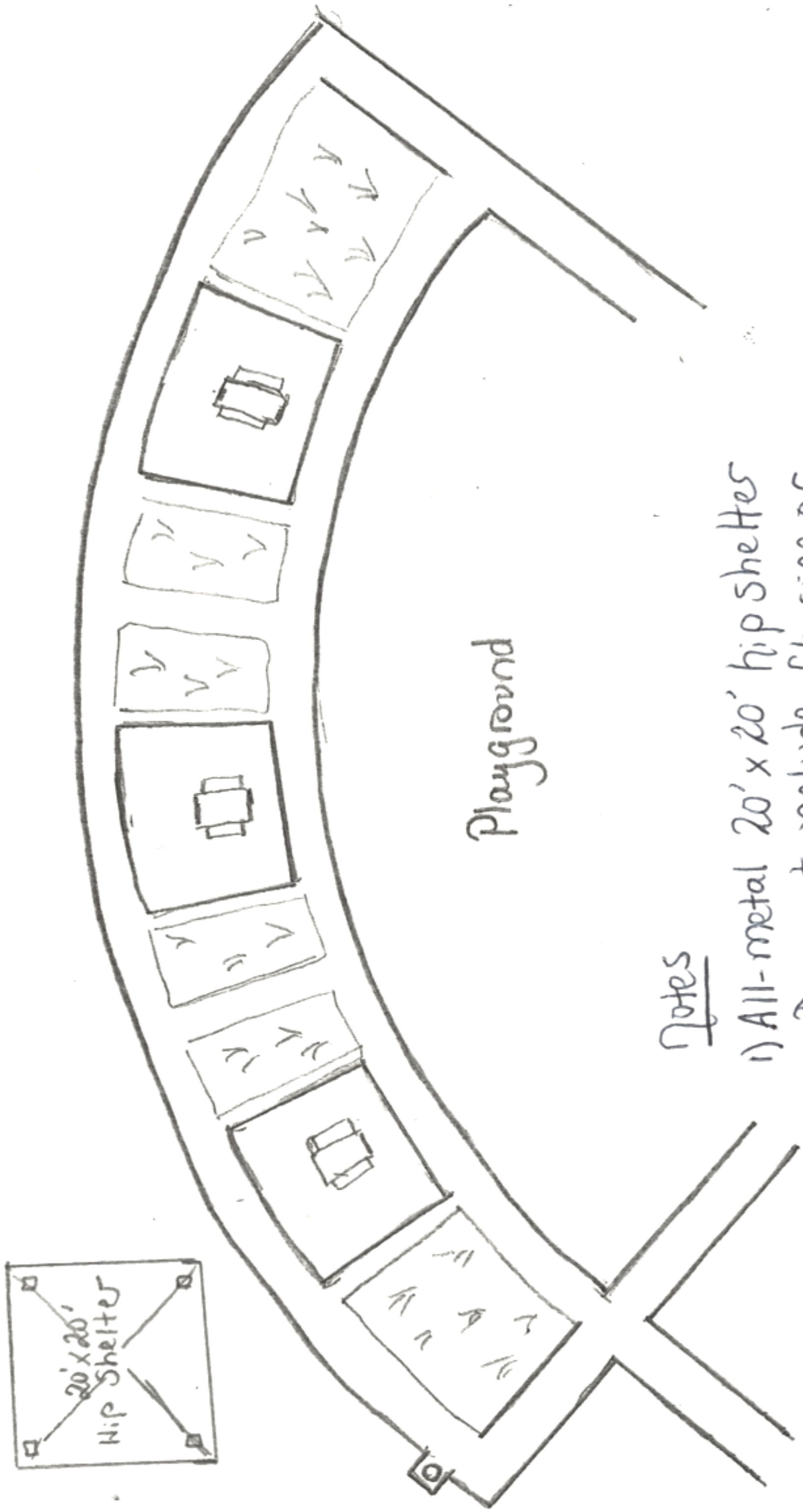

## Notes

- 1) All-metal 20' x 20' hip shelter  
Does not include flooring or site furnishings.
- 2) Assumes on-site disposal of spoils
- 3) Customer is responsible for confirming any local zoning or permitting requirements prior to placing order.

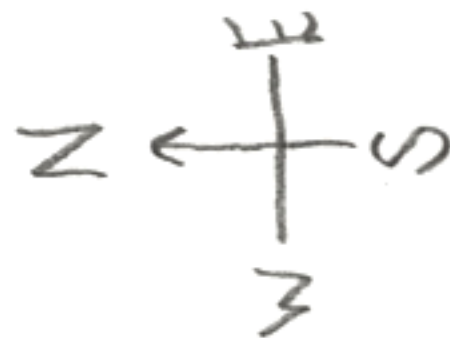

# SUPERIOR<sup>®</sup>

## RECREATIONAL PRODUCTS

PROJECT: TBD

LOCATION: TBD

BUILDING TYPE: 4S20-AS

ROOF TYPE: MULTI-RIB



### DRAWING LIST:

SHEET NUMBER	DRAWING DESCRIPTION
CS	COVER SHEET
1	ARCHITECTURAL ELEVATIONS
2	STRUCTURAL FRAMING PLAN
3	COLUMN LAYOUT

#### FABRICATOR APPROVALS:

CITY OF PHOENIX, AZ APPROVED FABRICATOR #C08-2010  
 CITY OF LOS ANGELES, CA APPROVED FABRICATOR #1596  
 CITY OF RIVERSIDE, CA APPROVED FABRICATOR #SP06-0033  
 CITY OF HOUSTON, TX APPROVED FABRICATOR #470  
 CLARK COUNTY, NV APPROVED FABRICATOR #264  
 STATE OF UTAH APPROVED FABRICATOR 02008-14

#### CERTIFICATES:

MIAMI-DADE COUNTY CERTIFICATE OF COMPETENCY NO. 13-0813.16  
 PCI (POWDER COATING INSTITUTE) 4000 CERTIFIED

#### MATERIALS:

DESCRIPTION	ASTM DESIGNATION
TUBE STEEL	A500 (GRADE B)
SCHEDULE PIPE	A53 (GRADE B)
RMT PIPE	A519
LIGHT GAGE COLD FORMED	A1003 (GRADE 50)
STRUCTURAL STEEL PLATE	A36
ROOF PANELS (STEEL)	A653

#### GENERAL NOTES:

UNLESS NOTED OTHERWISE, THIS STRUCTURE WAS DESIGNED TO ONLY SUPPORT WHAT IS SHOWN ON THESE DRAWINGS. SRP MUST BE CONTACTED IF ANYTHING ELSE IS TO BE ATTACHED TO THIS STRUCTURE (WALLS, COLUMN WRAPS, RAILINGS, ETC.) SO THE DESIGN OF THIS STRUCTURE CAN BE REVIEWED AND POSSIBLY REVISED.

UNLESS NOTED OTHERWISE, THIS STRUCTURE WAS DESIGNED ASSUMING A 20' SEPARATION BETWEEN ANY ADJACENT STRUCTURE WITH AN EAVE HEIGHT EQUAL TO OR GREATER THAN THE EAVE HEIGHT OF THIS STRUCTURE. IF THAT SEPARATION DOES NOT EXIST, SRP MUST BE CONTACTED SO THE DESIGN OF THIS STRUCTURE CAN BE REVIEWED AND POSSIBLY REVISED.

STRUCTURAL STEEL SHALL BE DETAILED, FABRICATED, AND ERECTED IN ACCORDANCE WITH THE LATEST EDITION OF THE AMERICAN INSTITUTE OF STEEL CONSTRUCTION (AISC) SPECIFICATION MANUAL.

ALL WELDING IS PERFORMED BY AMERICAN WELDING SOCIETY CERTIFIED WELDERS AND CONFORMS TO THE LATEST EDITION OF AWS D1.1 OR D1.3 AS REQUIRED.

PARTS SHOWN MAY BE UPGRADED DUE TO STANDARDIZED FABRICATION. REFER TO THE SHIPPING BILL OF MATERIALS FOR POSSIBLE SUBSTITUTIONS.

FOR PROPER FIELD INSTALLATION OF THE BUILDING IT IS RECOMMENDED THAT THE PRIMARY FRAME INSTALLER AND THE ROOF INSTALLER HAVE A MINIMUM FIVE (5) YEARS DOCUMENTED EXPERIENCE INSTALLING THIS TYPE OF PRODUCT.

FOR PROPER FIELD INSTALLATION OF THE BUILDING IT IS RECOMMENDED THAT ELECTRIC WIRING, IF REQUIRED, BE RUN THROUGH THE STRUCTURAL MEMBERS BEFORE THE BUILDING IS ERECTED.

**STOP!!**  
**NOT FOR CONSTRUCTION**

**USE FOR PRELIMINARY  
 PLANNING AND ESTIMATING  
 ONLY**

DRAWING: COVER SHEET		REV LEVEL: A
SCALE: NTS		
<b>SUPERIOR<sup>®</sup></b> RECREATIONAL PRODUCTS <small>COPYRIGHT 2016                  PATENTED OR PATENTS PENDING                  SUPERIOR RECREATIONAL PRODUCTS 1050 COLUMBIA DR. CARROLLTON, GA 30117</small>		(866)341-4364 www.srpshelter.com A <b>PLAYCORE</b> Company SHEET <b>CS</b>

**GENERAL ROOF NOTES:**

1. METAL ROOFING:  
24 GAUGE  
GALVALUME COATED  
KYNAR 500 PAINTED
2. TRIM COLOR MATCHES ROOF
3. SEE [SRPSHELTER.COM](http://SRPSHELTER.COM) FOR  
COLOR OPTIONS

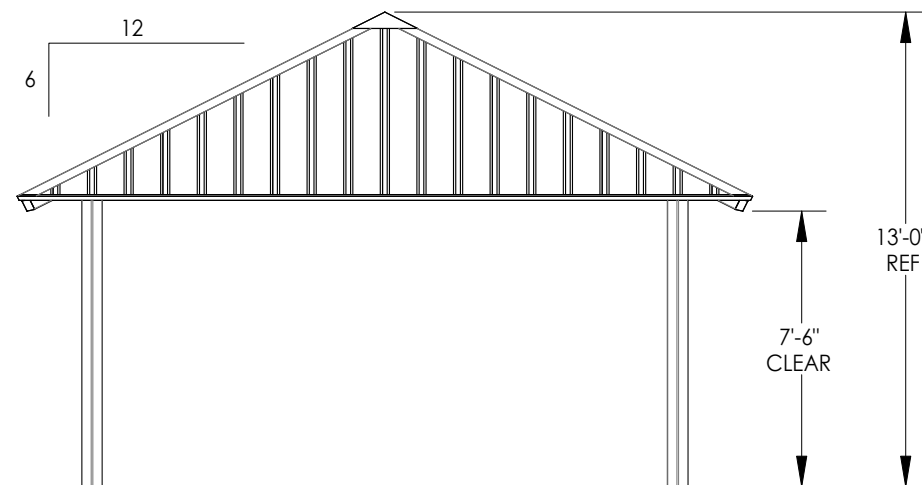
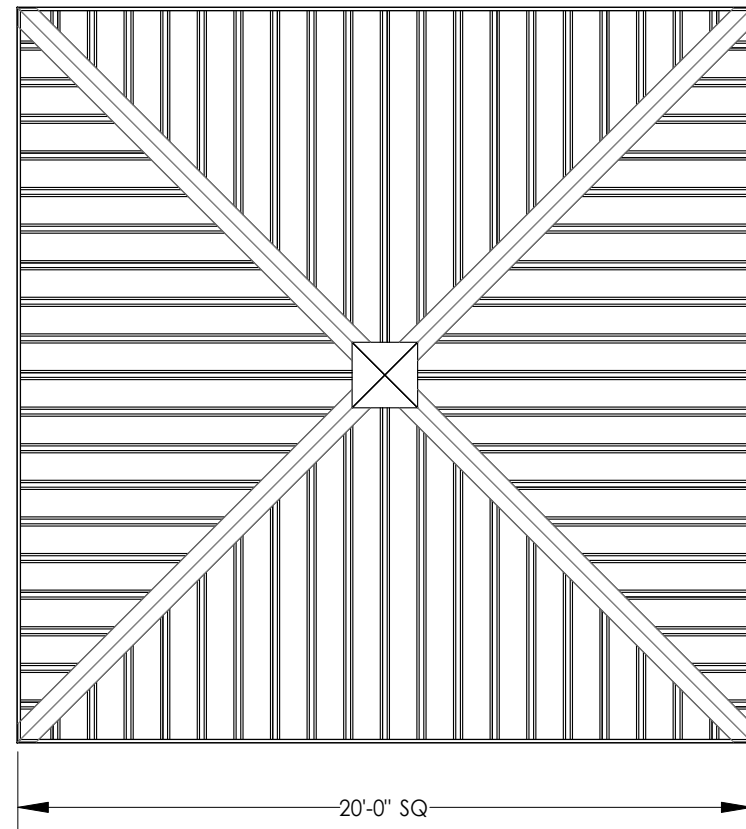

FINISH GRADE.  
MOUNTING VARIES  
BASED ON ENGINEERING  
REQUIREMENTS.

**STOP!!**  
**NOT FOR CONSTRUCTION**  
**USE FOR PRELIMINARY**  
**PLANNING AND ESTIMATING**  
**ONLY**

DRAWING: ARCHITECTURAL ELEVATIONS	
SCALE: NTS	REV LEVEL: A
SUPERIOR <sup>®</sup> RECREATIONAL PRODUCTS (866)341-4364 www.srpshelter.com COPYRIGHT 2016 PATENTED OR PATENTS PENDING SUPERIOR RECREATIONAL PRODUCTS 1050 COLUMBIA DR. CARROLLTON, GA 30117	
A PLAYCORE Company	
SHEET <b>1</b>	

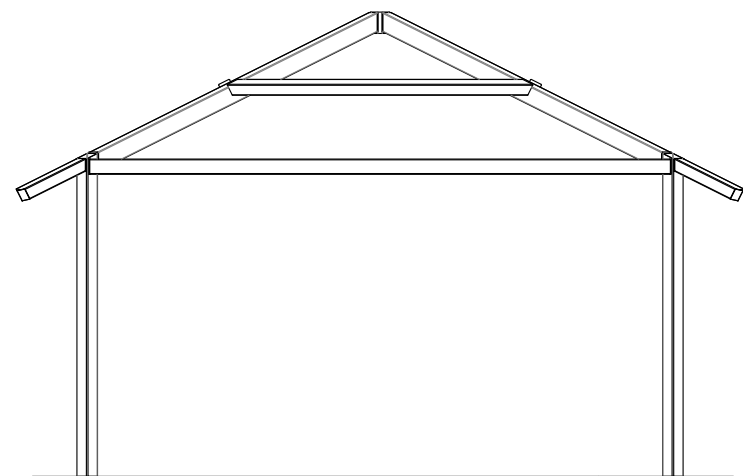
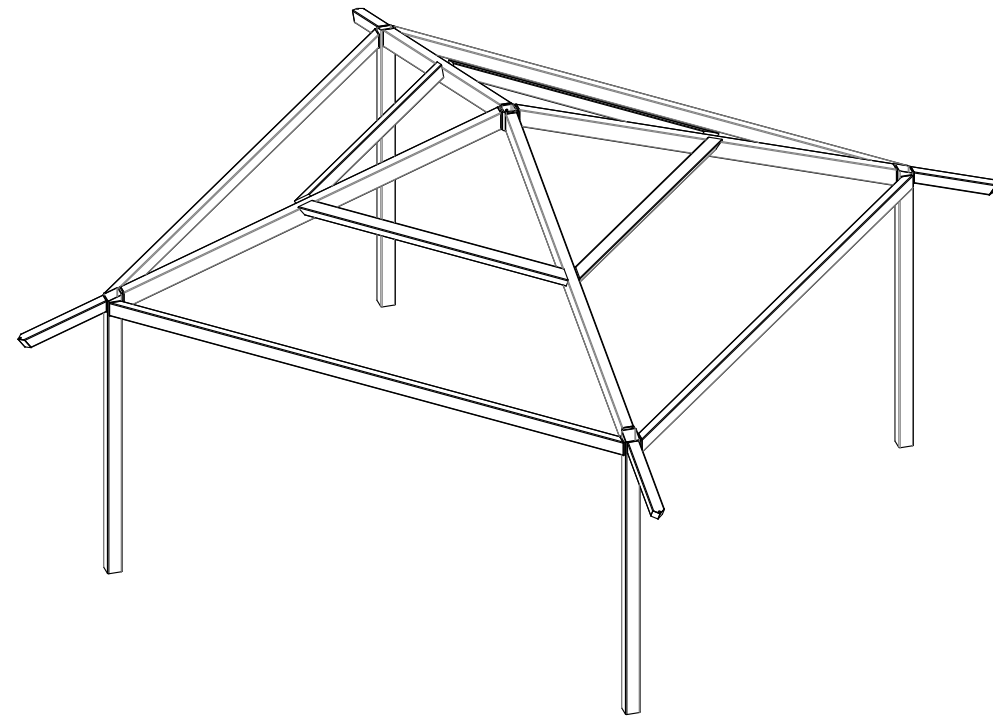
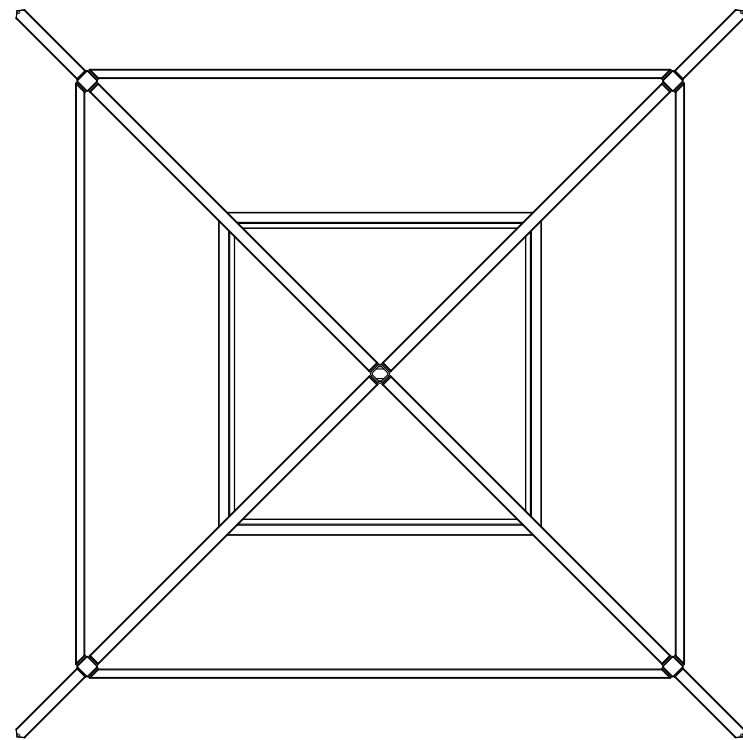

FINISH GRADE.  
MOUNTING VARIES  
BASED ON ENGINEERING  
REQUIREMENTS.

**STOP!!**  
NOT FOR CONSTRUCTION  
  
USE FOR PRELIMINARY  
PLANNING AND ESTIMATING  
ONLY

DRAWING: STRUCTURAL FRAMING PLAN	
SCALE: NTS	REV LEVEL: A
<b>SUPERIOR</b> <sup>®</sup> RECREATIONAL PRODUCTS <small>COPYRIGHT 2016 PATENTED OR PATENTS PENDING SUPERIOR RECREATIONAL PRODUCTS 1050 COLUMBIA DR. CARROLLTON, GA 30117</small>	
(866)341-4364 <a href="http://www.srpshelter.com">www.srpshelter.com</a>	<small>SHEET</small> <b>2</b>

**BASEPLATE NOTES:**

- 1. SRP ENGINEERING WILL DETERMINE REQUIRED BASEPLATE DESIGN AFTER ENGINEERING PACKAGE IS ORDERED.
- 2. CUSTOMER MAY SUGGEST PREFERRED BASEPLATE DESIGN.

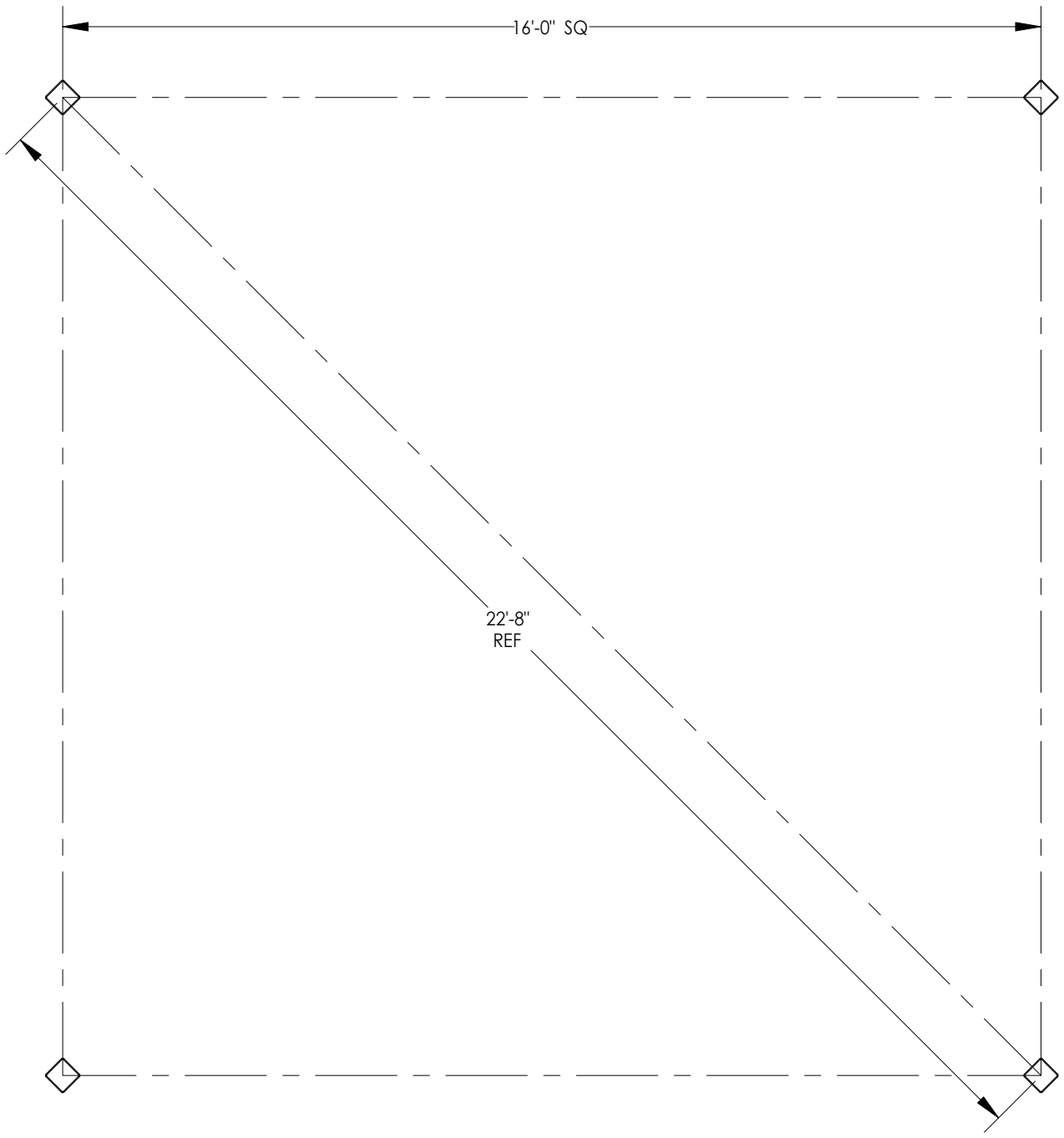

**STOP!!**  
**NOT FOR CONSTRUCTION**  
**USE FOR PRELIMINARY**  
**PLANNING AND ESTIMATING**  
**ONLY**

DRAWING: COLUMN LAYOUT		REV LEVEL: A
SCALE: NTS		
<b>SUPERIOR</b> RECREATIONAL PRODUCTS		(866)341-4364 <a href="http://www.srpshelter.com">www.srpshelter.com</a>
COPYRIGHT 2016 PATENTED OR PATENTS PENDING		A <b>PLAYCORE</b> Company
SUPERIOR RECREATIONAL PRODUCTS 1050 COLUMBIA DR. CARROLLTON, GA 30117		SHEET <b>3</b>



**SUPERIOR<sup>®</sup>**  
RECREATIONAL PRODUCTS

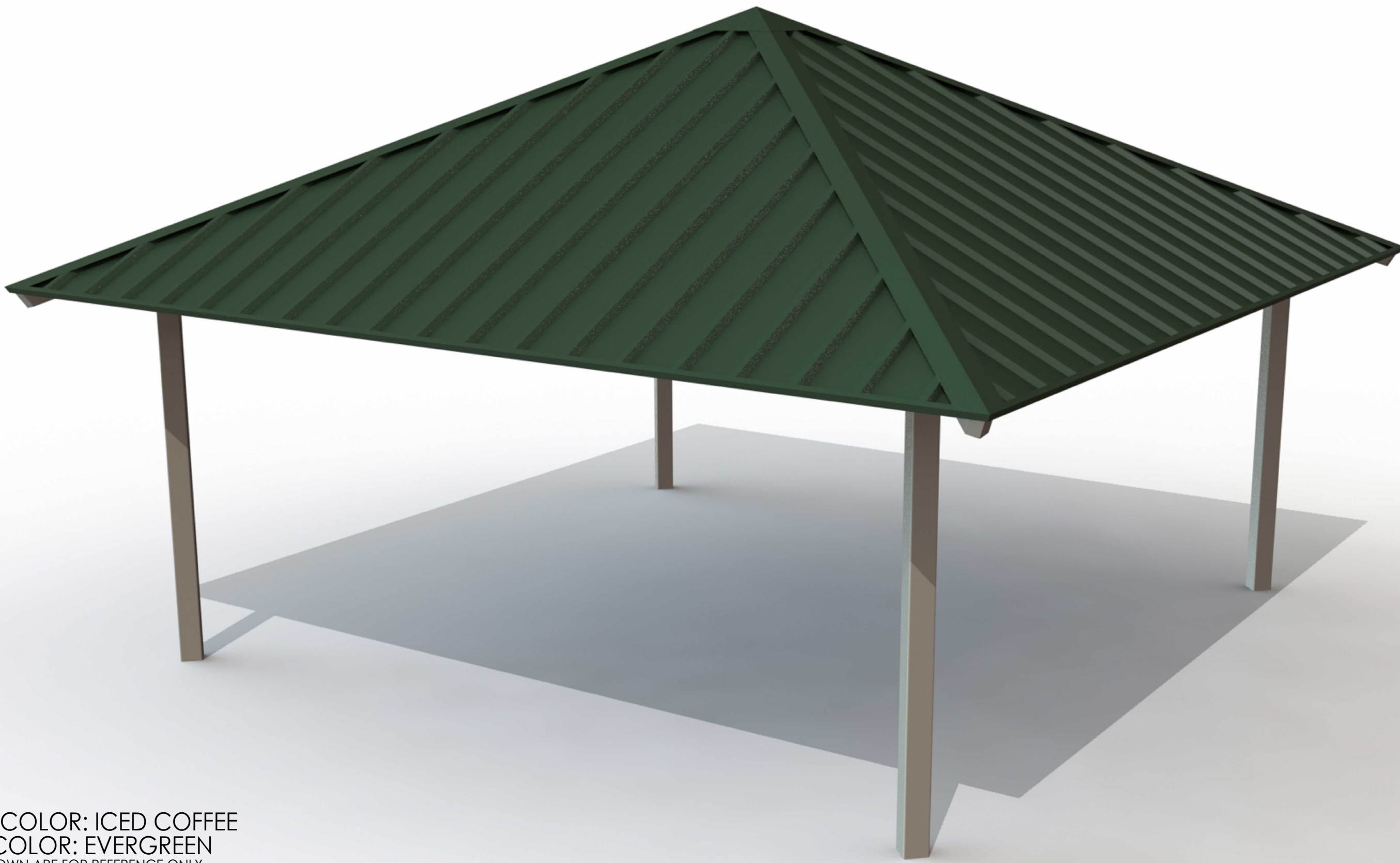

FRAME COLOR: ICED COFFEE  
ROOF COLOR: EVERGREEN  
COLORS SHOWN ARE FOR REFERENCE ONLY.  
CONTACT [ShadeAndShelter@SIBBrands.com](mailto:ShadeAndShelter@SIBBrands.com)  
TO REQUEST ACTUAL COLOR SAMPLES.

4S20-AS

# Traditional Shade Fabric Colors



\*Not California Fire Marshal certified

# Frame Color Options



\*Semi-gloss finish.

# Superior Shelter

## ALL-STEEL SHELTER METAL ROOF COLORS

### 24 Gauge R-Panel Profile

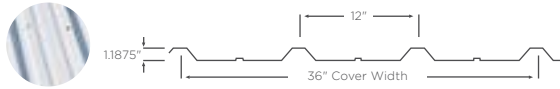

### 24 Gauge Medallion-Lok Profile



- |  |               |  |                  |  |               |  |              |  |                |
|--|---------------|--|------------------|--|---------------|--|--------------|--|----------------|
|  | Regal White   |  | Patrician Bronze |  | Sandstone     |  | Brandywine   |  | Hartford Green |
|  | Bone White    |  | Charcoal         |  | Light Stone   |  | Colonial Red |  | Evergreen      |
|  | Matte Black   |  | Slate Gray       |  | Copper Penny* |  | Bright Red   |  | Patina Green   |
|  | Dark Bronze   |  | Ash Gray         |  | Mansard Brown |  | Regal Blue   |  | Galvalume Plus |
|  | Medium Bronze |  | Surrey Beige     |  | Tudor Brown   |  | Roman Blue   |  |                |

\*Upcharge

## STEEL FRAMES

### Gloss

- |  |              |  |            |  |                 |  |                  |
|--|--------------|--|------------|--|-----------------|--|------------------|
|  | Red          |  | Patina     |  | Blue            |  | Iced Coffee      |
|  | Orange       |  | Green      |  | Deep Periwinkle |  | Brown            |
|  | Butterscotch |  | Sage       |  | Electric Purple |  | Patrician Bronze |
|  | Yellow       |  | Deep Green |  | Burgundy        |  | Black            |
|  | Spring Green |  | Ocean Blue |  | Terracotta      |  | White            |

### Matte, Textured, or Metallic

- |  |               |  |                 |
|--|---------------|--|-----------------|
|  | Feather Gray  |  | Starry Night    |
|  | Iron Gray     |  | Textured Black  |
|  | Rubbed Bronze |  | Textured Bronze |

Colors are approximate. Ask your representative for an actual color sample.





Go Play, Inc  
 Jennifer and David VanWormer  
 9916 County Road 48 1/2  
 Milliken, CO 80543

Pool  
 Cantilever shade  
**Proposal**

Customer	
Name	Ventana Metro District - c/o Walker Schooler District Mng.
Address	614 N. Tejon Street
City	Colorado Springs State CO ZIP 80903
Phone	(719)447-1777 ext. 103 (Rebecca Hardekopf)

Misc	
Date	622/2021
Order No.	SRPSSQ22
Rep	JVW
FOB	

Qty	Description	Unit Price	TOTAL
2	<b>EQUIPMENT:</b> Superior Shade 20' x 20' square, single-post cantilever shade umbrella, 8' eave height, 6" sub-surface mount.  FRAME COLOR - _____ SHADE FABRIC COLOR - _____	\$7,640.00	\$ 15,280.00
1	<b>Go Play Discount on 20' Square Cantilever Umbrella</b> <i>May not be combined with any other discounts or promotions.</i>	10%	\$ (1,528.00)
1	Sealed engineered drawings (1 set per style and location needed)	\$700.00	\$ 700.00
1	Manufacturer's steel surcharge <i>(If order is placed with deposit by 7/11/21, deduct \$900)</i>		\$ 2,040.00
2	<b>INSTALLATION:</b> Complete installation of shade structures above by Go Play, Inc. including (1) standard size footing not to exceed 3.5' diameter x 3' depth, one mobilization to site and complete installation of frame and canopy.  <b>Installation location:</b> <u>Ventana Pool, 11007 Hidden Prairie Parkway Fountain, CO 80817</u>  <b>NOTES:</b> Signature below indicates approval of order for size, style and color of shades described above. Installation price assumes adequate access to site for large installation machinery and does not include turf protection. No site preparation, locating or repairing existing drain or sprinkler lines, fencing, security, concrete cutting, concrete patching, concrete flatwork, removal or disposal of spoils, nor site restoration are included. Should sealed engineered drawing require larger than standard size footing piers for this location, additional fees will apply. No permits, licenses, taxes or associated fees are included. Current lead time on seals is running 4 weeks and production lead time is 6-8 weeks. Lead times may vary without notice due to shortages in the supply chain and workforce.	\$3,650.00	\$ 7,300.00

**Signed proposal and 50% deposit is required to proceed with order.**

Date \_\_\_\_\_

Tax Rate(s)

SubTotal	\$ 23,792.00
Freight	\$ 2,895.00
2.90%	exempt
<b>Total</b>	<b>\$ 26,687.00</b>

Authorizing Signature \_\_\_\_\_

Tax Exempt # \_\_\_\_\_ \*

*\*If customer is not exempt from sales tax, applicable tax will be added to materials.*

Office Use Only



CONTACT- Go Play Phone (970) 587-5963  
 Go Play Email [jennifer@goplayplaygrounds.com](mailto:jennifer@goplayplaygrounds.com)



Thank you for your consideration! Quoted pricing is valid for 30 days unless otherwise noted.

### Square Cantilever Umbrella Shade

Length	20	Width	20	Entry Height	8
Peak Height	12.04	Elbow	Glide	Column Mount	Base Plate
Column Size	8080.25	Rafter Size	3.511	Ridge Size	3.511
Column Length	8.5	Rafter Length	14.7313913	Ridge Length	0

Dome Qty: 1 Column Qty: 1

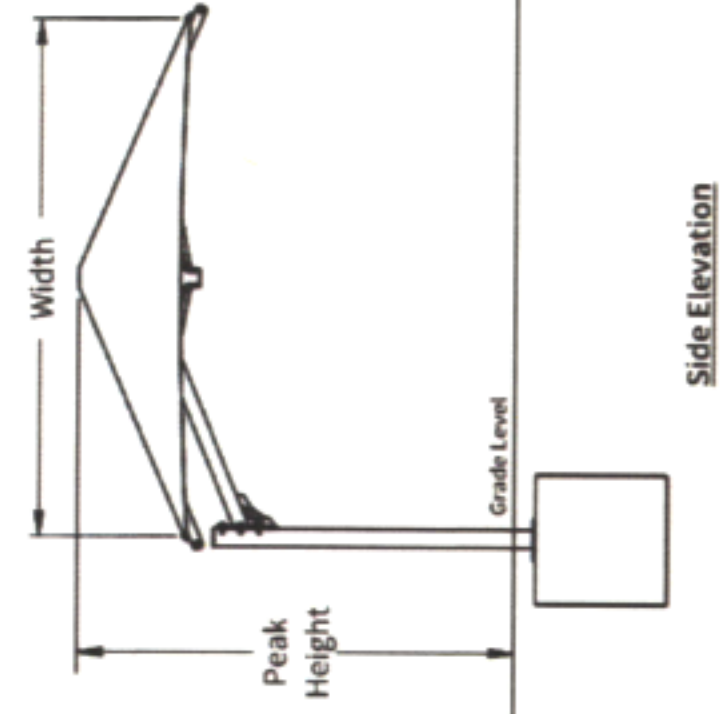
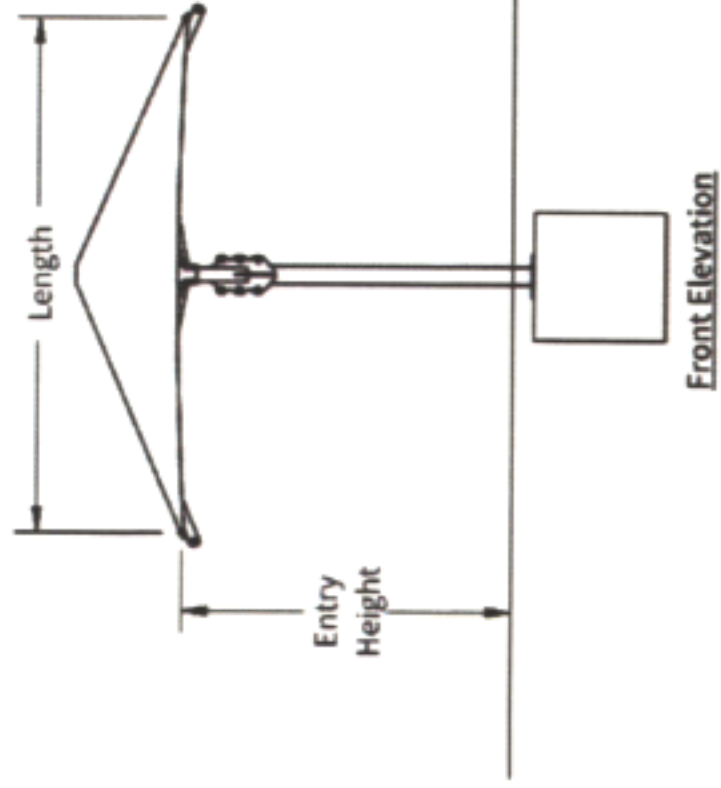
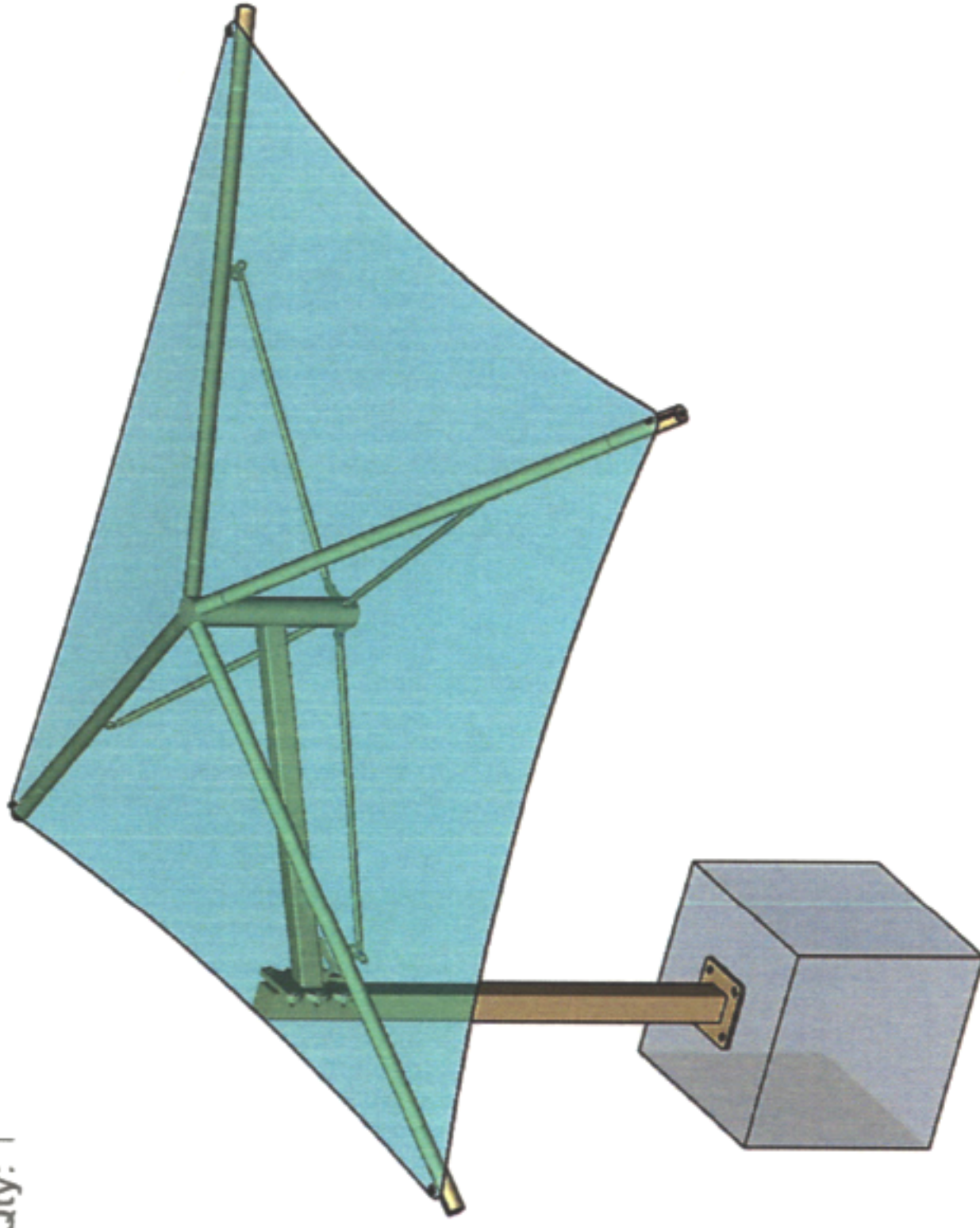

# SHADE

BY SUPERIOR RECREATIONAL PRODUCTS

QUOTE

SHADE SIZE  
20 X 20

SHADE STYLE  
Square Cantilever  
Umbrella Shade

*These drawings are for reference only and should not be used as construction details. They show the general character and rough dimensions of the structural features. Exact spans, fasteners, materials, and foundations can be determined by a licensed professional engineer upon request. Estimated footing size above is based on 1,500 PSF soil bearing pressure.*



Square Footing		
Column	Length & Width	Depth
Single Cap	5.56	3
Double Cap	N/A	3

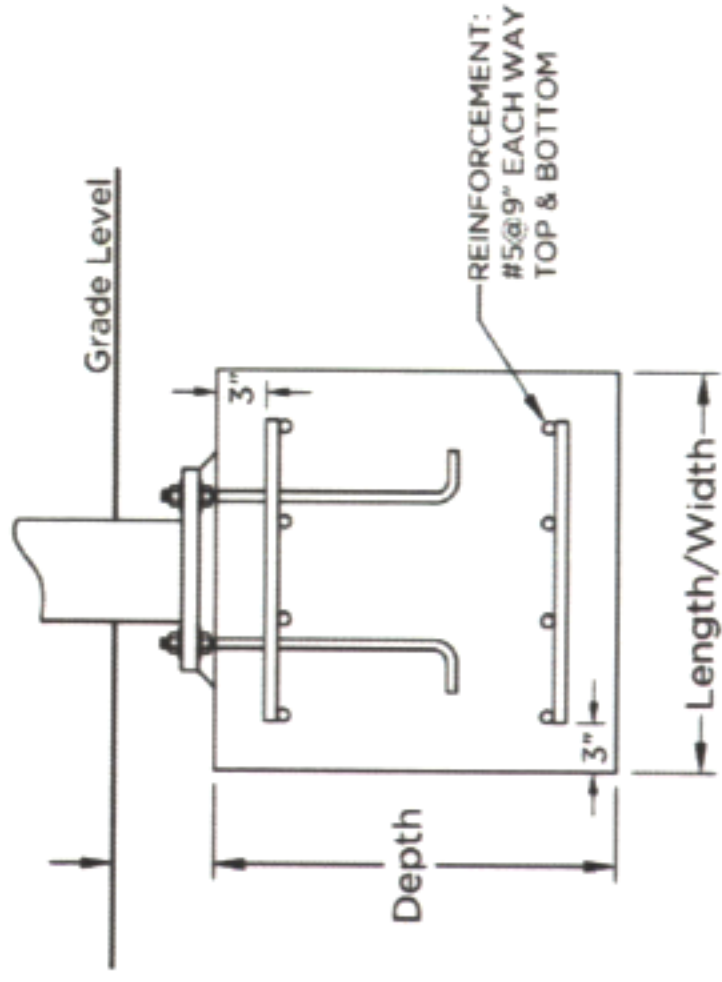

Auger Footing		
Diameter	Single Cap Depth	Double Cap Depth
1'-6"	Out of range	N/A
2'-6"	Out of range	N/A
3'-0"	10.51	N/A

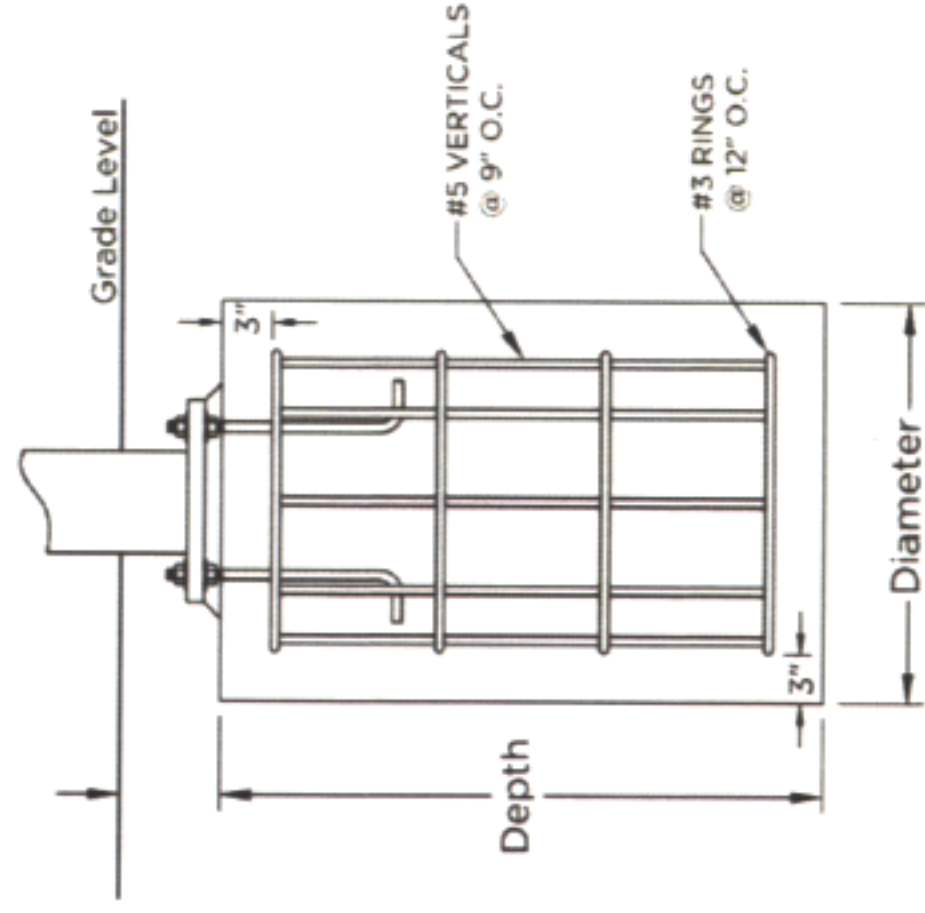

# Ventana Metro District Pool Shade

**GO PLAY, INC.**  
Jennifer VanWormer  
(970) 587-5963  
jennifer@goplayplaygrounds.com

Building

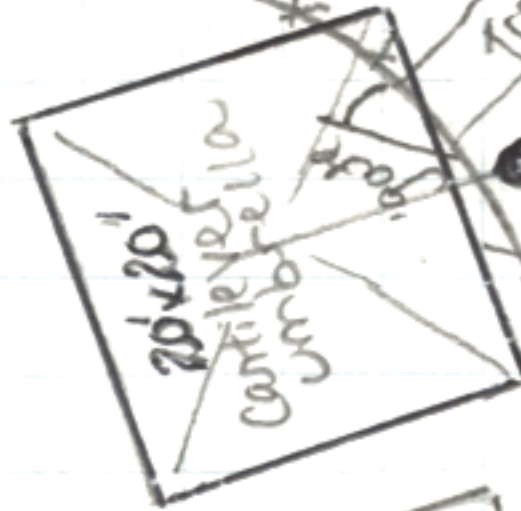
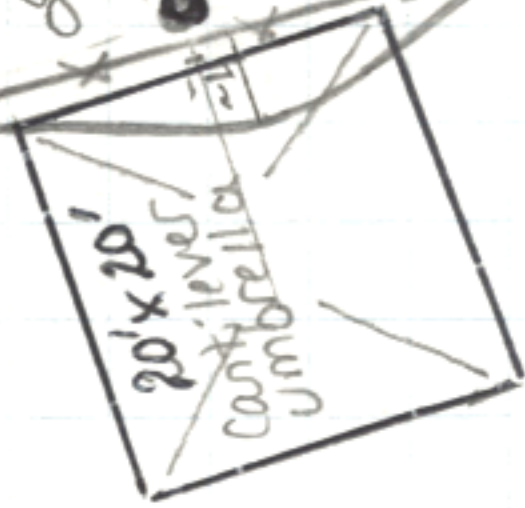

Alternate location (if possible)

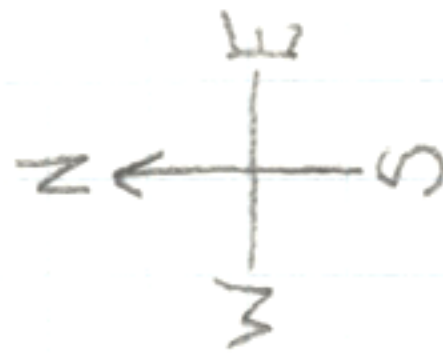

Pool

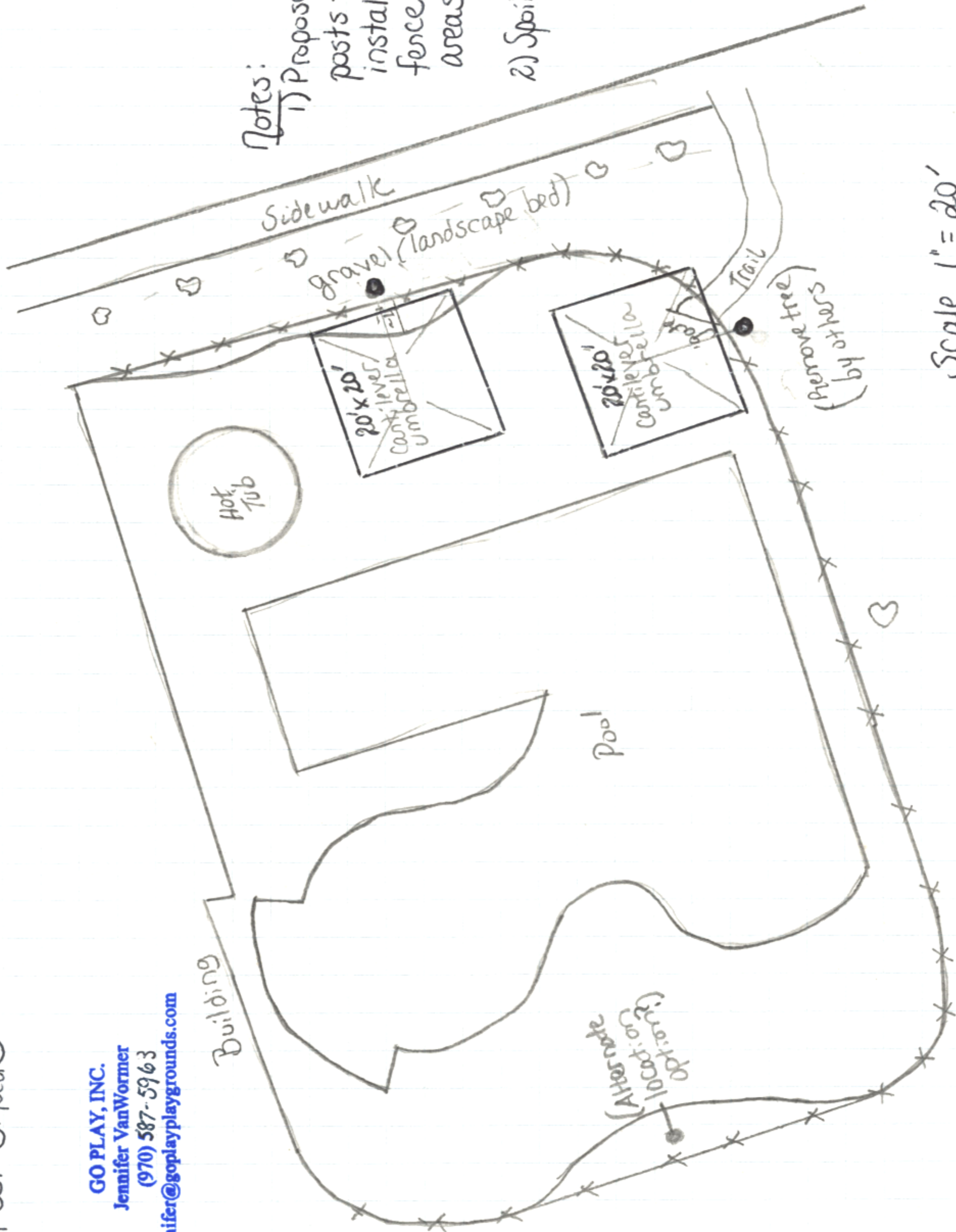

Notes:

1) Proposed shade posts to be installed outside fence in landscape areas.

2) Spoils to remain on site.

Scale 1" = 20'





## Rebecca Hardekopf

---

**From:** Blaine Marcoulier <blaine@weisburg.com>  
**Sent:** Tuesday, July 6, 2021 2:36 PM  
**To:** Rebecca Hardekopf; Riley Walker  
**Subject:** Ventana Dog Station Pricing

Hello-

Here is some pricing for purchasing and installing dog stations, \$515 each, includes the pole, can and bag dispenser on top, you have been waiting for a while on this pricing so thanks for your patience's. Let me know how many and where?

Thanks,

**Blaine Marcoulier, CLT**

*Weisburg Landscape Maintenance*

*Field Account Manager*

*Office 719-596-7777*

*Cell 719-649-0320*



INTEGRITY  
PROFESSIONALISM  
BEAUTIFUL LANDSCAPES





## Ventana Metro District

Bid Date: 7/8/2021 \*Pricing is good for 90 days

### Install Gorilla Hair Mulch- Area 1

Description	Materials			Labor & Equipment			Haul, Dump, Delivery		Total
	qty	unit	subtotal	unit	hours	subtotal	qty	rate	
Mulch Install- Gorilla Hair	1.5	cuyd	\$ 119.37	crew hrs per cuyd	1.2	\$ 86.63	1	\$ 80.00	\$ 286.00

**Notes:** These 6 areas need re-mulched to hide the exposed drip line, help with weed control, retain more moisture and look better overall. You can approve by area or all at once. **Total: \$ 286.00**

### Install Gorilla Hair Mulch- Area 2

Description	Materials			Labor & Equipment			Haul, Dump, Delivery		Total
	qty	unit	subtotal	unit	hours	subtotal	qty	rate	
Mulch Install- Gorilla Hair	1.5	cuyd	\$ 119.37	crew hrs per cuyd	1.2	\$ 86.63	1	\$ 80.00	\$ 286.00

**Total: \$ 286.00**

### Install Gorilla Hair Mulch- Area 3

Description	Materials			Labor & Equipment			Haul, Dump, Delivery		Total
	qty	unit	subtotal	unit	hours	subtotal	qty	rate	
Mulch Install- Gorilla Hair	4.5	cuyd	\$ 358.11	crew hrs per cuyd	3.7	\$ 259.88	1	\$ 80.00	\$ 697.99

**Total: \$ 697.99**

### Install Gorilla Hair Mulch- Area 4

Description	Materials			Labor & Equipment			Haul, Dump, Delivery		Total
	qty	unit	subtotal	unit	hours	subtotal	qty	rate	
Mulch Install- Gorilla Hair	46	cuyd	\$ 3,660.68	crew hrs per cuyd	38.0	\$ 2,656.50	3	\$ 114.75	\$ 6,661.43

**Total: \$ 6,661.43**

### Install Gorilla Hair Mulch- Area 5

Description	Materials			Labor & Equipment			Haul, Dump, Delivery		Total
	qty	unit	subtotal	unit	hours	subtotal	qty	rate	
Mulch Install- Gorilla Hair	26.5	cuyd	\$ 2,108.87	crew hrs per cuyd	21.9	\$ 1,530.38	2	\$ 114.75	\$ 3,868.75

**Total: \$ 3,868.75**

### Install Gorilla Hair Mulch- Area 6

Description	Materials			Labor & Equipment			Haul, Dump, Delivery		Total
	qty	unit	subtotal	unit	hours	subtotal	qty	rate	
Mulch Install- Gorilla Hair	2.25	cuyd	\$ 179.06	crew hrs per cuyd	1.9	\$ 129.94	1	\$ 114.75	\$ 423.74

**Total: \$ 423.74**

**Grand Total: \$ 12,223.89**

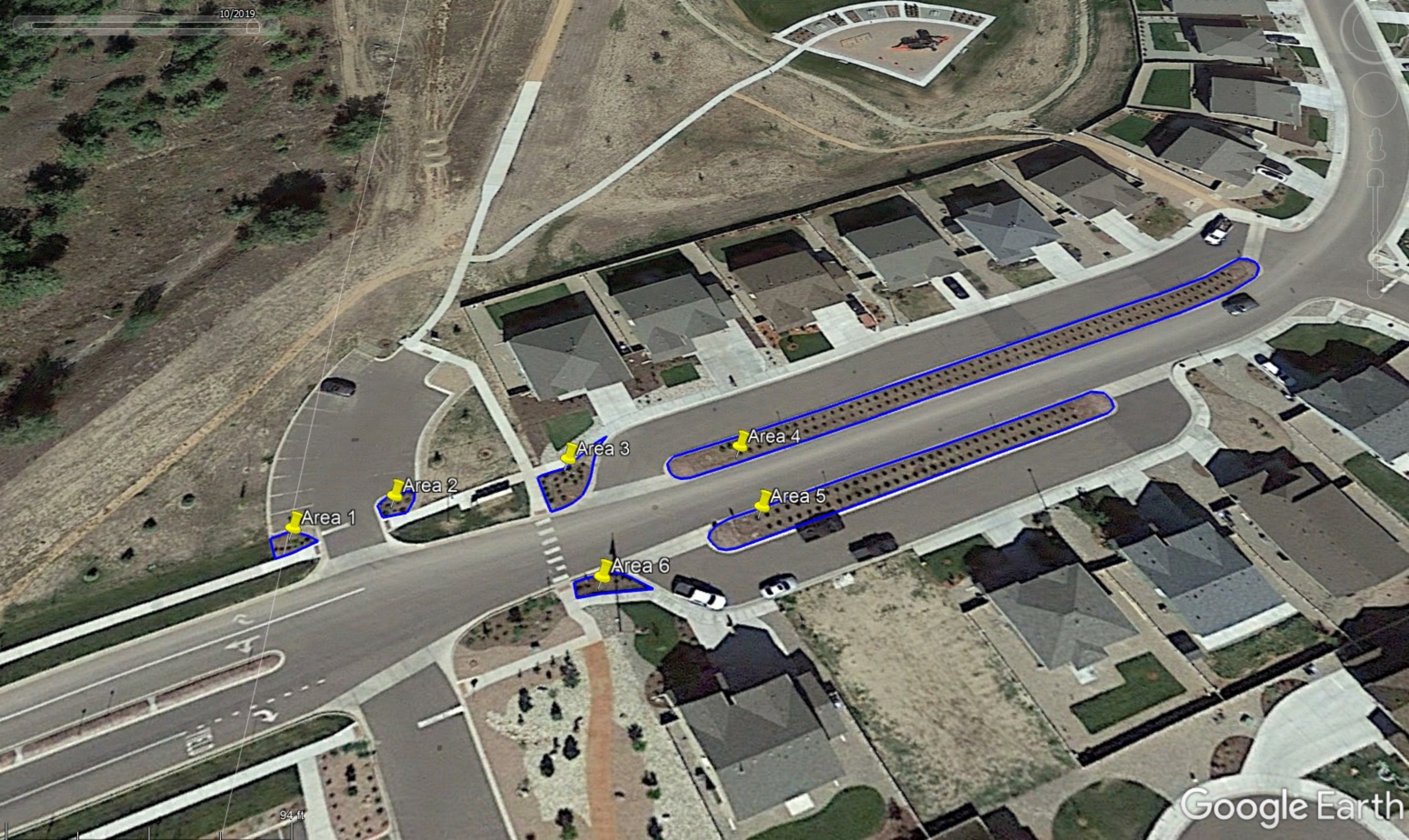

94 ft



## Ledgend

- WSDM Manager recomendation
- City of Fountain recomendation

